

FREQUENCY INVERTER

E800

0,2kW – 110kW (IP20)

*Safety instructions Installation
& operating manual*

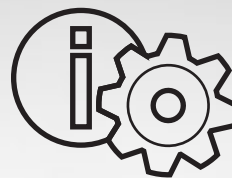

BLU S.r.l.

Via dell'Artigianato , 37 30030 VIGONOVO (VE)

Ph. +39 049 9800318 Fax. +30 049 9800319

Email: info@bludrive.it Web : www.bludrive.it

ENGLISH

E800 – Rev.01 -EN- SOFT Rev. 2.04

INDEX

PAGE

1) Common installation- and safety rules for series E2000/3000 inverters	1
2) Product data / product range	10
3) Inverter mounting	15
4) Electrical connection of E2000 Inverters	16
5) Control-board – hardware and I/O channel configuration	23
6) Operating panel	29
7) Inverter parametrization	31
8) Parameter group 100: Basic parameter	32
9) Parameter group 200: Inverter control	38
10) Parameter group 300: Digital I/O configuration	43
11) Parametergruppe 400: Analogue I/O channel configuration	47
12) Parameter group 500: Fixed-frequency, automatic cycling frequencies	51
13) Parameter group 600: DC-Bake control / Aux. functions	52
14) Parameter group 700: Error handling and protection functions	55
15) Parameter group 800: Autotuning – Motor data programming	59
16) Parameter group 900: RS485 Hardware and interface parameters	61
17) Parameter group A00: PID controller parameter	62
19) Diagnostic functions	65

Rev. 01 -DE- 2015 KPP
Softwarerevision: 2.04

1) Common installation- and safety rules for Blu inverters, series E800

IMPORTANT!!

This instruction manual explains rules for correct installation and safe operation of frequency inverters, series E800 (denominated inverter, or drive in the following guidance). It is mandatory to follow exactly, what reported in this instruction manual.

This instruction manual must be read and fully understood before any action of installation or placing in operation of the inverter.

Anybody, who operates the inverter, or the machine, equipped with inverter, must have access to this operation manual, and must become familiar with drives technology, especially regarding safety and warning issues

All instructions in this manual must be observed, to:

Guarantee safety for humans and machinery
Allow safe function and reliable operation
Permit approvals and certifications
Keep manufacturers warranty in force

Following pictograms are used in this instruction manual:

DANGER-WARNING-CAUTION

ATTENTION: Life or health of the user are endangered or substantial damage to property may occur.



ATTENTION – OBSERVE

Measures, necessary for safe and trouble-free operation



Common:

DANGER



Frequency inverters operate with voltages, hazardous to humans
Depending on inverters protection degree (IP class) and mounting conditions, life parts may be accessible.
During heavy duty operation, and especially in case of malfunction, parts/surfaces of inverters or accessory may reach dangerous temperatures, which may result in personnel injury.
Inadmissible removal of covers or other parts of the inverter, improper use, and not qualified mounting or operation may result in high risk for personnel injury and/or machinery damage

DANGER



All activity for mounting, cabling, placing into operation and operation of the inverter must be done exclusively by proper educated and trained people.

The standards IEC 364 and/or CENELEC HD384, DIN VDE 0100 and all other national safety standards are to observe.

Trained people has specific professional training, knowledge of all relevant standards and safety rules and experience in application of electrical/electronic drive systems.
These professionals are in condition to judge assigned duties, and resulting risks.

Specified application of frequency inverters

DANGER



The inverters, reported in this manual are components of electrical/electronic drive systems and determinate for integration in machines and plants only.

The E800 serves exclusively for the control and regulation of three phase motors (asynchronous / synchronus motors)
The connection of loads, other than above listed, may result in damage of the machinery, destruction of the inverter or connected equipment, and serious risk of personnel injury.

Observe specific standards and rules

DANGER



It is not allowed, to place in operation the plant, before the compliance with all standards of the machinery safety regulation (89/392/EWG) and the EMC rules (89/336/EWG) has been checked

Inverters are conformal with low voltage directive (73/231/EWG).
Harmonized standards EN50178 (VDE160) and EN60439-1 (VDE0660, T. 500) are applied.

BLU DRIVES E800 is a product with limited availability (in sense of IEC 61800-3). Frequency inverters may create high frequency noise, in case the operator is responsible for proper countermeasures.

Handling, transportation and storage

DANGER



Inverter components may become damaged and insulating distances may be reduced, as a result of improper transportation, handling or storage of the drive.

In this case, the inverter does not anymore comply with product specific standards and rules, and it is not allowed to place it into operation.

Therefore it is mandatory, to check the inverter for mechanical integrity, before installation and operation.

The inverter may contain components, sensitive to electrostatic discharge. Therefore avoid, touch components inside the drive.

It is recommended to store the inverter, using the original box. If inverters are stored or out of use for more then one year, DC capacitors may lose their capacity. Please contact the inverter manufacturer for reformatting procedure

Installation of the inverter

DANGER



Frequency inverters must be installed in a proper cabinet.

Only fixed installation is permitted.

Follow all effective standards and rules for correct grounding!!

All minimum distances to other inverters or equipment in the cabinet are to respect. Minimum distances are reported later on this manual.

Allow adequate air circulating, especially, in case of vertical mounting, one on top of the other.

Use proper shielded cables, for inverter control signals and feed back signals

Intrusion of dust, liquids, water, steam and aggressive gases must be excluded

Attention on adequate heat exchange of the cabinet

Use of the inverter in explosion risky area is not allowed

Electrical wiring of frequency inverters

DANGER HAZARDOUS CAPACITOR CHARGE

The entire plant must be disconnected from power, crosschecked for loss of voltage and locked before starting any work



The discharge time of the internal DC-LINK capacitors may take up to 5 minutes, it is not allowed to open the enclosures or to do any maintenance work during discharge cycle!!

LVD – DOUBLE INSULATON



All connection terminals for control and feed-back are single insulated in sense of EN50178.

In case of connection to external equipment with double insulation, the user has to provide proper arrangement, to guarantee double insulation in sense of EN50178 for the whole system

GROUNDING



E800 inverters are designed for steady state installation, using fixed wiring. It is not allowed, to use power plug or similar mobile connection.

Depending on different EMC filter arrangements, the leakage current to ground may exceed 3,5 mA. Therefore it is recommended to use earth connection wiring, with minimum section of 10mm² (copper) or use double wiring (in sense of EN50178)

All grounding connections must be as short as possible, all leading to one common central point (star arrangement).

Long motor leads

A motor cable length, exceeding **30m**, may result in over-voltage spikes on the motor side. These peaks may damage the internal insulation of the motor.

The use of motor chokes, sinus filter or dV/dt limiting filters may prevent from risk of motor damage.

Generally it is recommended, to use inverter duty motors
In case of any doubt, please contact the manufacturer



All output filter components must have inverter manufactures approval

1) Common installation rules and safety information regarding BLU E800 inverters



Insulation testing

In case of insulation testing of the whole network, it is recommended to disconnect the inverter and all optionally mounted filter components. Some components, used inside the inverter may impact measurement accuracy, or may become destroyed

All BLU inverters have to pass the insulation test, according to EN15178, during the final test procedure on the production line.



Potential equalization

If components with no galvanic insulation are used and connected to the inverter, proper measures are necessary, to guarantee potential equalization.

**DANGER OF FIRE
BURNS**



Braking resistors

All kinetic energy of the system converts to heat, during braking cycle. This energy dissipates in the braking resistor. Improper dimensioning of the braking resistor or insufficient heat exchange may result in high risk of fire

Also over-voltage on the input power supply may lead to high risk of fire

Therefore all braking resistor must have two thermistors, series connected, which contacts open in case of over-temperature, disconnecting the whole power supply, on inverters input terminals

Braking resistors surface may become very hot, even during normal operation. Therefore it is necessary to mount the resistor in a safe location, using proper protecting cages.

**IMPACT ON
DIFFERENTIAL
CURRENT
BRAKERS**



Differential current breaker (FI)

The use of frequency inverters may delay or even inhibit the trigger of differential current breakers.

For life protection, all plant with inverters must have following:

Input wiring protection: Fuses or automatic over-current breaker (Dimensioning: see tables).

Differential current protection: "All-sensitive" protectors (braker), minimum requirement type „B“ , mounted on all inverter power lines.

It is not permitted to connect other equipment on inverter power lines.

For single phase inverters (230V class) the use of differential current breaker type "A" or "F" is allowed.

The trigger current of the differential current breaker depends on the operating frequency, motor type, PWM frequency and the length of the motor cable

It is recommended, to use differential current breaker with 300 mA threshold (for industrial environment).

Basic rules for reliable and safe operation

- Proper dimensioning of the system (motor, inverter, mechanical elements).
- Check for correct inverters rated voltage, consider tolerances too
- Review all inverter and motor cabling, including correct terminal tightening torque (torque values: see table).
- Use proper cable for all control wiring, separate control cable from power cable, min. 15 cm distance. Use shielded cable for all control connections, exceeding 1 meter
- Twist wires to braking resistors or use shielded cables
- Shielded cables are recommended for motor connection too, especially with distances, exceeding 30 meters.
- Avoid earth loops, all earth connections should have large contact areas, all leading to one central grounding point (star connected)

**IMPORTANT FOR
SAVE INVERTER
OPERATION**



One separate circuit breaker is recommended for each inverter – allowing separate switch off of single inverters.

CHECK FOR PROPER INVERTER PROGRAMMING

Improper programming of the inverter may result in unpredictable behavior of the system and subsequent high risk of damage and/or personnel injury.

The inverter may be enabled for multiple automatic restart attempts in case of fault – delayed restart is possible.

Unpredictable systems reactions may become the result of internal inverter defects.

The inverter may ignore commands, speed, STOP instructions, or signals originated from external components.

The braking function of the inverter may fail.

Depending on the application, external safety components, working independently from the inverter, are required, to guarantee the safety of the whole system

Inverter protection-functions

Although the inverter is equipped with intelligent protections functions, the repetitive triggering of those functions may result in inverter damage.

The inverter is protected against output short circuit and earth fault, each displayed by a specific code on the display.

Repetitive earth faults and short circuits may damage the power stage of the inverter.

The motor must be fixed connected, in case, where interruption of the motor line is required (for safety reason), the circuit should open/close with inverter in STOP condition only (final stage disabled).

It is recommended, to keep the inverter powered on at all time, if for application reason repetitive power on cycling is required, it should not exceed one cycles every 5 minutes – otherwise contact the manufacturer.



1) Common installation rules and safety information regarding BLU E800 inverters



Power-grid specification:

The inverter is built for symmetric three phase power supply systems, with voltage phase to earth/neutral not exceeding 300V. A transformer can be used for adaptation to higher voltages. For single phase inverters the maximum input voltage is 240V +15%, 400V class three phase inverters can work up to 460V +15%. Contact the inverter manufacturer, before connecting to unbalanced, floating, or unsymmetrical power systems.



Power supply – short circuit capability

Input chokes ($U_k=4\%$) are recommended to connect the inverter on a power grid with high short circuit capability, this especially for continuous operation.

If the power supply capability exceeds by 20 times the inverter power, the use of chokes is mandatory.

Measurements on inverter input and output:

Current and voltage may have no sinus shaped waveform on inverters input/output side.

If improper testing instruments are used, the result may become inaccurate, or in worst case, the inverter and/or the test instrument may become destroyed.

On input side, the current waveform is composed by fundamental and harmonics, while on output side the voltage waveform is PWM modulated.

The used instruments must be able to handle the various signal waveforms. For simple measurements, a high quality moving iron instrument could be suitable.

**FOR ANY QUESTION –
CONTACT THE
MANUFACTURER**

The inverter manufacturer must be contacted in case of any question, regarding this safety/instruction manual, or if some parts have not been fully understood.



Please ask before installing or placing on operation the system.

This is mandatory, to avoid any risk for machinery damage and/or personnel injury.

EMC: Basics and recommendations for installation

The E800 series inverters are electrical devices, designed for installation in industrial area. E800 inverters are not designed to work stand alone, these inverters are considered as part of a complex system, for this reason, no separate EMC marking is applied on the inverter. The machine builder / system integrator is obligated to prove the compliance with actual EMC standards for the whole system.

Normally, the inverter integrated EMC filters are sufficient, to meet the actual EMC limits (this has been confirmed by measurements, performed by independent body).

Inverters E800 are designed for use in "second environment", (in sense of EN61800-3). This means installation in industrial area, where power supply is done via separate transformer.

Fore installation in "first environment" (residential area – public low voltage power grid), additional filter components may become necessary, to meet EMC rules.

EMC - adequate installation

Mounting in metal cabinet, if possible, the cabinet should be divided into power and control area, using metal shielding barrier, or similar

Connect all metal parts, grounding cables, cable shields on one central point, using the blank mounting plate as contact area.

Use 10mm² cables for potential equalization, "star" connected on one central point. Please consider, that inverters and filters may have more than 3,5 mA leakage current, therefore use proper earthing / grounding conductors:

Grounding conductor min. 10 mm² (copper)
Grounding connection with separate monitoring system, which disconnects automatically in case of fault.
Dual grounding, using separate cable and terminals.

Use shielded cables, wherever possible, with copper mesh, common cable steel protection is not working as shield.

Connect shields on large blank areas with potential equalization bars. Use special cable glands, with integrated contact brushes.
It is not allowed to extend cable shield, using single wire.

Mount all external filter components as close as possible to the noise source (inverter) – get perfect contact, mounting directly on the blank cabinet plate.

Keep all wiring as short as possible, separate different networks, min. 15 cm distance. Different networks are: power supply, motor cable (incl. brake resistor), low voltage control wiring (control signals, feed back, data line).

Twist all unshielded cables
Unused wires in cables should be connected to ground

Inverters with UL mark: Additional information

Following information are valid for inverters, designed for use in countries, which require UL approval. All information below must be available to all who are responsible for commercialization, installation and place in operation.

UL Standards

The UL/cUL mark applies to products in the United States and Canada and it means that UL has performed product testing and evaluation and determined that their stringent standards for product safety have been met. For a product to receive UL certification, all components inside that product must also receive UL certification.



UL Standards Compliance

This drive has been tested in accordance with UL standard UL508C, File No. E363934 and complies with UL requirements. To ensure continued compliance when using this drive in combination with other equipment, meet the following conditions:

- 1) Do not install the drive to an area greater than pollution severity 2 (UL standard)
- 2) Installation and operating instructions shall be provided with each device.

The following markings shall appear in one of the following locations: shipped separately with the device; on a separable, self-adhesive permanent label that is shipped with the device; or anywhere on the device itself.

- a) Designation markings for each wiring diagram;
- b) Markings for proper wiring connections.
- c) "Maximum Surrounding Air Temperature 40°C." or equivalent;
- d) "Solid State motor overload protection reacts when reaches 150% of FLA" or equivalent;
- e) "Install device in pollution degree 2 environment." or equivalent;
- f) For Models of Frame Size (E800-0007T3UBR;E800-0011T3 UBR;E800-0015T3 UBR;E800-0022T3UBR): "Suitable For Use On A Circuit Capable Of Delivering Not More Than 5,000 rms Symmetrical Amperes, 480 Volts Maximum When Protected By made by COOPER BUSSMANN L L C Class T Fuse: JJS-15." or equivalent.
For Models of Frame Size (E800-0030T3UBR;E800-0037T3UBR;E800-0040T3UBR): "Suitable For Use On A Circuit Capable Of Delivering Not More Than 5,000 rms Symmetrical Amperes, 480 Volts Maximum When Protected By made by COOPER BUSSMANN L L C Class T Fuse: JJS-25." or equivalent.
For Models of Frame Size (E800-0055T3UBR;E800-0075T3UBR): "Suitable For Use On A Circuit Capable Of Delivering Not More Than 5,000 rms Symmetrical Amperes, 480 Volts Maximum When Protected By made by COOPER BUSSMANN L L C Class T Fuse: JJS-35." or equivalent..
- g) "Integral solid state short circuit protection does not provide branch circuit protection. Branch circuit protection must be provided in accordance with the National Electrical Code and any additional local codes" or the equivalent;
- h) "CAUTION – Risk of Electric Shock" should be provided, followed by instructions to discharge the Bus Capacitor or indicating the time required (5 minutes) for Bus Capacitor to discharge to a level below 50 Vdc;
- i) "Drives have no provision for motor over temperature protection" or equivalent;
- j) For used in Canada only: "TRANSIENT SURGE SUPPRESSION SHALL BE INSTALLED ON THE LINE SIDE OF THIS EQUIPMENT AND SHALL BE RATED __480__ V (PHASE TO GROUND), 480 V (PHASE TO PHASE), SUITABLE FOR OVERVOLTAGE CATEGORY _III_, AND SHALL PROVIDE PROTECTION FOR A RATED IMPULSE WITHSTAND VOLTAGE PEAK OF _6 kV" or equivalent.

Field Wiring Terminal Markings – Wiring terminals shall be marked to indicate the proper connections for power supply and load, or a wiring diagram coded to the terminal marking shall be securely attached to the device:

- a. "Use 60/75°C CU wire" or equivalent;
- b. Required wire torque, type and range listed: see chapter 4) *Empfohlene Leitungsquerschnitte – Sicherungen Leistungsklemmen*

Grounding – The wire connector intended for ground connection for field installed equipment, shall be clearly identified such as being marked "G", "GRD", "Ground", "Grounding", or equivalent or with the grounding symbol (IEC 417, Symbol 5019).

Tightening torque and wire section for field grounding wiring are marked adjacent to the terminal or on the wiring diagram.

2) Product data / product range

Product naming convention

E800 - 0007 S2

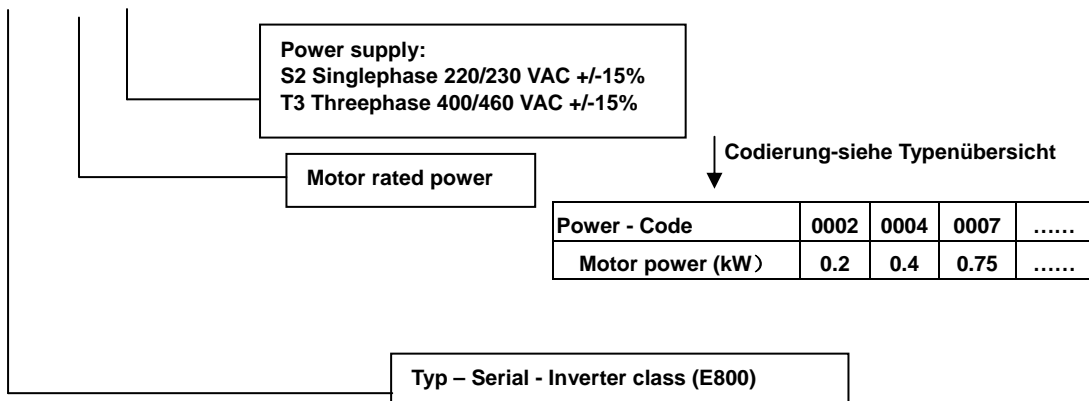

Options identifier

D F2 Y K B R

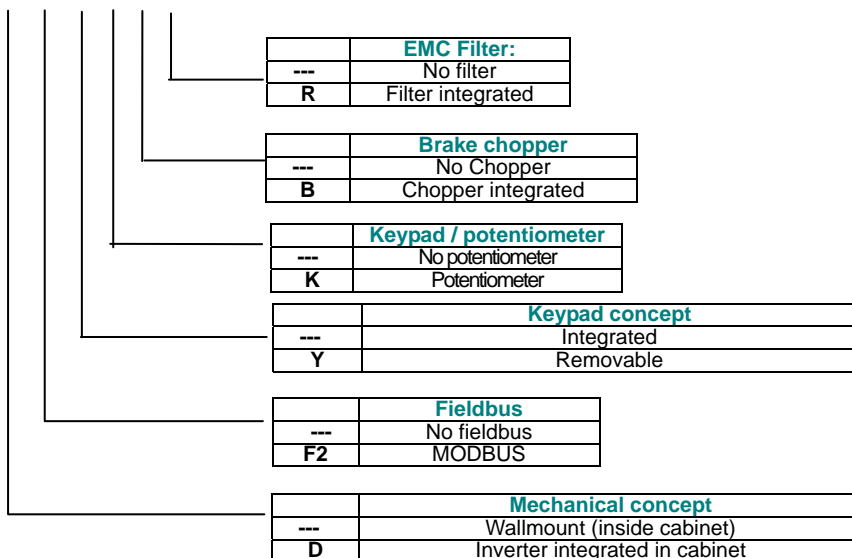

Nameplate

The adjacent picture shows a typical nameplate of a series E800, single phase, 230V 1,5 kW inverter, 7A rated current, including following options: F1 (MODBUS), B (Brake-chopper) R (integrated EMC-Filter)

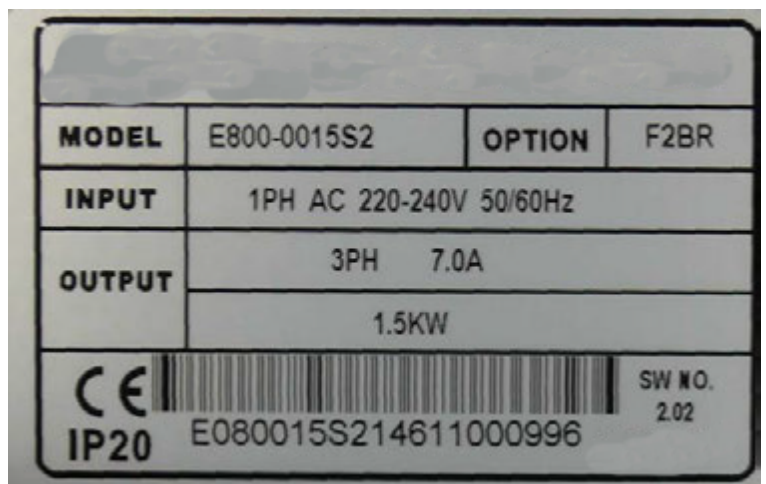

2) Product data / Product range

Mechanical construction

There are two different basic concepts:

Inverter with power range from 0,75 to 22 kW: POLYCARBONATE enclosure, build on a constructional base (heatsink) with the keypad integrated on the cover (not removable) – **framesize E1 – E6**

Inverter with power range from 18,5 to 90 kW: Steel panel, power and control terminals inside, with the keypad integrated in the cover and removable - **framesize C3 – C6**

Appearance of an E800 - Size E2 inverter



2) Product data / Product range

Appearance of an E800 - Size E8 inverter

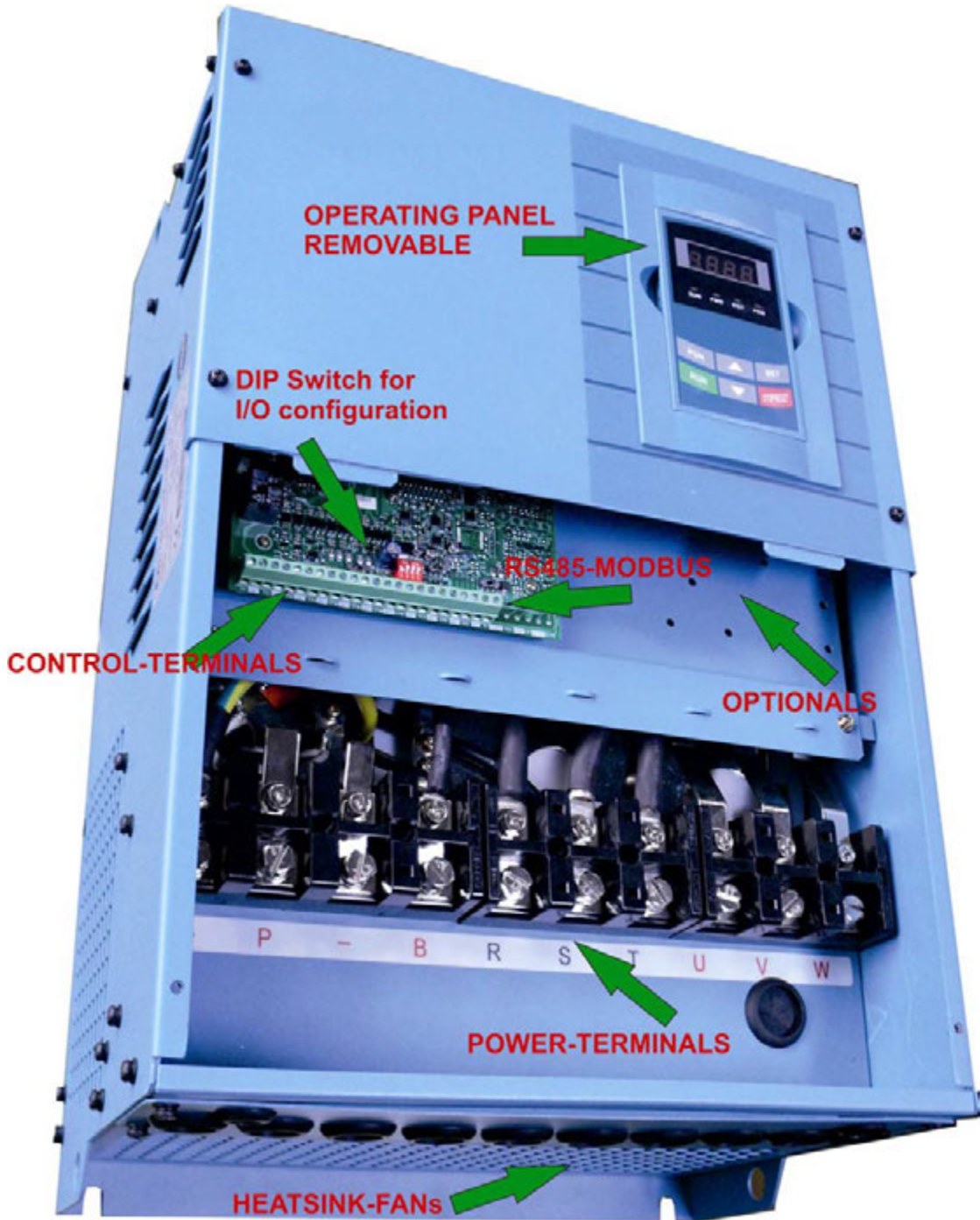

2) Product data / Product range

Technical data – inverter series E800

Power supply	Rated voltage	3-Phase 380...460V - 3 Ph. 220...240V - 1Ph. 220...240V - Tol. +/- 15%
	Input frequency	44...67 Hz
	EMC filter	Integrated for 2. Environment – C3 (up to 90 kW)
Output	Output voltage	0.....U-input
	Output frequency	0.....650 Hz
	Resolution of output frequency	0,01 Hz
	Overload capability	120% - 60 sec. / 10 Min
Control mode	PWM control-modes	V/Hz - Mode Permanentmagnet Synchronmotor control (Software option)
	PWM frequency	0,8...10 kHz
	V/Hz characteristic	Linear, quadratic, and user-programmable curve
	Torque boost	Automatic / Manual
	Motor data input	Manual input / intelligent AUTOTUNING function
	DC-Brake	Freq. threshold, duration and intensity programmable
Display	Brake chopper	Integrated chopper transistor (Brake resistors – see product table)
	7 Segment LED display -4- digit	For programming and visualization of different operating parameters
I/O Channels, control functions	Inverter control - Start/Stop	To configure: terminals / operation panel / serial link
	Digital control inputs	8 (5) digital inputs (HIGH/LOW configurable), pulse input
	Speed reference signal	Potentiometer (on operating panel / Extern), analogue input (terminals), operating panel keys, pulse input, serial link
	Reference analogue channels	2 Analogue channels 12 BIT 0...10V, 0..(4)20 mA (with programmable offset, gain – to concatenate mathematically each other)
	Analogue outputs	2 (1) analogue output channels, both programmable in gain, different functions to assign (0...10V, 0..20 mA)
	Digitale outputs	2 (1) digital outputs (different functions to assign)
	Relays output	1 switchover contact 5 A 230 V (programmable for different functions)
	Interface	Serial link (MODBUS – ASCII/RTU)
	Special function - control options	Jog mode, 12V / 50 mA auxiliary power supply on terminals PI-control Fixed frequency control "Catch on the fly function", AUTORESET/RESTART functions
Protection functions, incl. fault memory	Electrical protection functions	Overvoltage, Undervoltage
		Overcurrent, Overload, Motor-Overload, Output-short
	Phase loss, Motor-Phase imbalance	
Thermal protection functions	Heatsink overtemperature – Motor overtemperature (PTC/KLIXON), Motor I ² xt	
Optionals	Operating panel	Remote keypad / programming tool
	Brake resistors	High power resistors for heavy duty operation
	Filter / chokes	PFC chokes – dv/dt limiting output filter - sinusfilter
	PC-Link Software (via MODBUS)	Special tool for programming, control and diagnostic (parameter set memory)
Environmental conditions	Protection	IP20 – IP21 (optional)
	Operating temperature	-10.....+50 °C
	Humidity	Max. 90 % not condensing, no corrosion
	Elavation	1000 m - 1% derating / 100m above
	Vibration	Max. 0,5 g
Power range		0,2.....400 kW
Standards	EMC	EN61800-3(2004)
	Safety	EN61800-5-1 2003

2) Product data / Product range

Product range - framesize

Inverter 230V – 1 Phase						
Model	Rated power / Current	Size	Enclosure	Dimensions (wxHxD - mm)	BR Chopp.	Minimum brake resistor value
E800-0002 S2	0,2 kW - 1,5A	E1	POLYCARBONATE	80x138x135	INTEGRATED	80 Ohm / 100W
E800-0004 S2	0,4 kW - 2,5A	E1				
E800-0007 S2	0,75 kW - 4,5A	E1				
E800-0011 S2	1,1 kW - 7A	E2		106x180x150		
E800-0015 S2	1,5 kW - 7A	E2				
E800-0022 S2	2,2 kW - 10A	E2				
Inverter 230V – 3 Phase						
Model	Rated power / Current	Size	Enclosure	Dimensions (WxHxD - mm)	BR Chopp.	Minimum brake resistor value
E800-0002 S2	0,2 kW - 1,5A	E1	POLYCARBONATE	80x138x135	INTEGRATED	80 Ohm / 100W
E800-0004 S2	0,4 kW - 2,5A	E1				
E800-0007 S2	0,75 kW - 4,5A	E1				
E800-0011 S2	1,1 kW - 7A	E2		106x180x150		
E800-0015 S2	1,5 kW - 7A	E2				
E800-0022 S2	2,2 kW - 10A	E2				

Inverter 400V – 3 Phase						
Model	Rated power / Current	Size	Enclosure	Dimensions (WxHxD - mm)	BR Chopp.	Minimum brake resistor value
E800-0002 T3	0,2 kW – 0,6 A	E1	POLYCARBONATE	80x138x135	INTEGRATED	200 Ohm / 100W
E800-0004 T3	0,4 kW – 1 A	E1				
E800-0005 T3	0,55 kW – 1,5 A	E1				
E800-0007 T3	0,75 kW - 2 A	E2		106x180x150		150 Ohm / 100W
E800-0011 T3	1,1 kW – 3 A	E2				
E800-0015 T3	1,5 kW – 4 A	E2				
E800-0022 T3	2,2 kW - 6,5 A	E2				
E800-0037 T3	3,0 kW - 8 A	E4		138x235x152		80 Ohm / 300W
E800-0040 T3	4,0 kW - 9 A	E4				
E800-0055 T3	5,5 kW - 12 A	E4		156x265x170		80 Ohm / 600W
E800-0075 T3	7,5 kW - 17 A	E5				
E800-0110 T3	11 kW - 23 A	E5		205x340x196		50 Ohm / 600W
E800-0150 T3	15 kW - 32 A	E6				
E800-0185 T3R	18,5 kW - 38 A	E6				
E800-0220 T3R	22 kW - 44 A	E6		270x435x235		20 Ohm / 1500W
E800-0300 T3R	30 kW - 60 A	C3				
E800-0370 T3R	37 kW - 75 A	C3				
E800-0450 T3R	45 kW - 90 A	C4				
E800-0550 T3R	55 kW - 110 A	C5	315x480x235	15 Ohm / 2000W		
E800-0750 T3R	75 kW - 150 A	C5				
E800-0900 T3R	90 kW - 180 A	C6	369x555x265	10 Ohm / 3000W		
			410x630x300	8 Ohm / 10000W		

3) Inverter mounting

3) Inverter mounting

Please read all, what reported on chapter 1) *Common installation- and safety rules for BLU DRIVES inverters, series E800* before proceeding with inverter mounting, cabinet wiring, and putting the system into service.

Mounting in cabinet

Accordingly to the protection degree class (IP20/21), the inverter must be placed in a proper cabinet.

The inverter should be mounted vertically, using all available mounting holes.

Avoid mounting of more inverters in vertical array. If absolutely necessary, keep double mounting distances

The table below, shows the minimum mounting distances in vertical and horizontal direction

Sufficient heat exchange of the cabinet must be guaranteed, to keep all operating conditions within the specified limits.

Framesize	Mounting	
<30kw	A≥150mm	B≥50mm
≥30kw	A≥200mm	B≥75mm

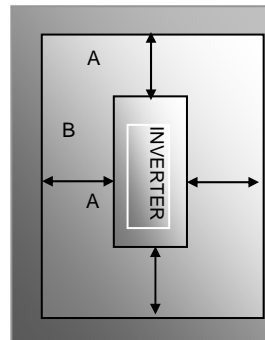

Distances for mounting in cabinet

Fans: All inverters out of the E800 series are forced ventilated. Specific parameters are used to set various fan operating modes: Allways ON (F702=2), ON with inverter in running mode (F702=1), or temperature controlled (F702=0) (F703=Temp. threshold)

see 14) *Parameter group 700: Error handling and protection functions (F702-F703)*

Maintenance and service:

Provided that the inverter is working in respect of specified environmental conditions, provided that the inverter is used for proper application, and all instructions have been exactly followed for installation, putting in service and operation, the inverter does not need any specific maintenance.

4) Electrical connection of E800 Inverters

E800 inverters have separate terminals for power- and control-connection. Adequate cables are requested for wiring the inverter, all safety rules, reported in the first chapter of this manual are to observe.

Power terminals:

There are different arrangements for power terminals, depending on inverter size and number of input phases.

230V Singlephase

0,2 – 0,75 kW – Framesize **E1**

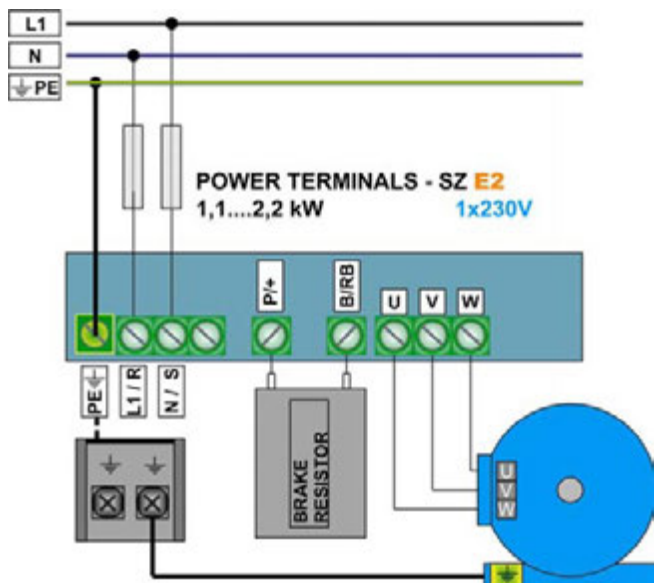

1,5 - 2,2 kW - Framesize **E2**

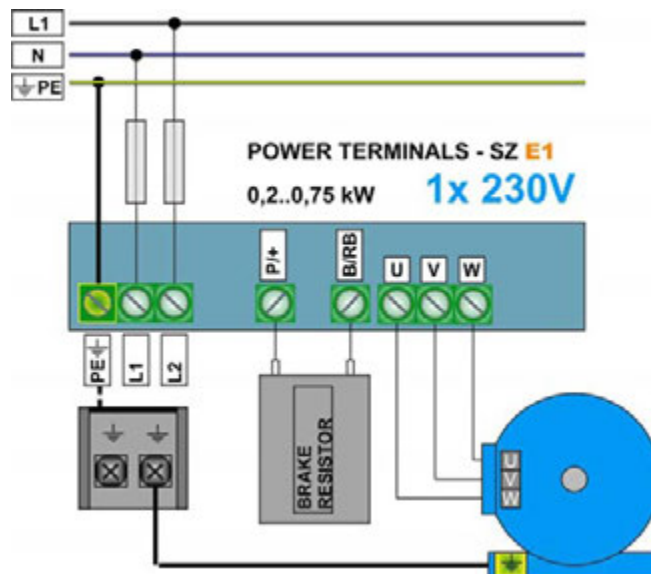

230V Threephase

0,2 – 0,75 kW – Framesize **E1**

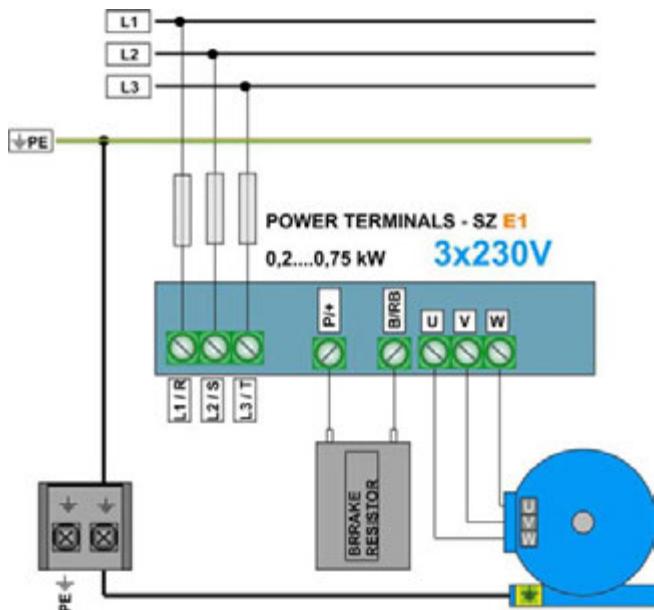

1,5 - 2,2 kW - Framesize **E2**

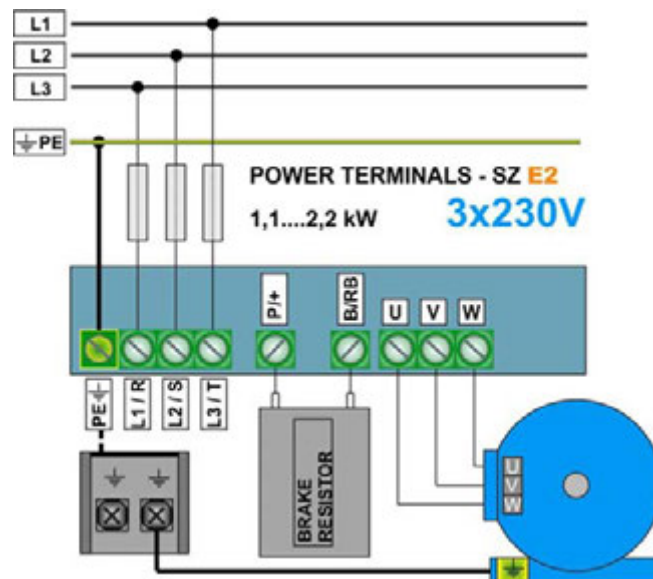

4) Electrical wiring of E800 inverters

400V Threephase

0,75 – 0,55 kW – Framesize E1

0,75 – 11 kW – Framesize E2-E5

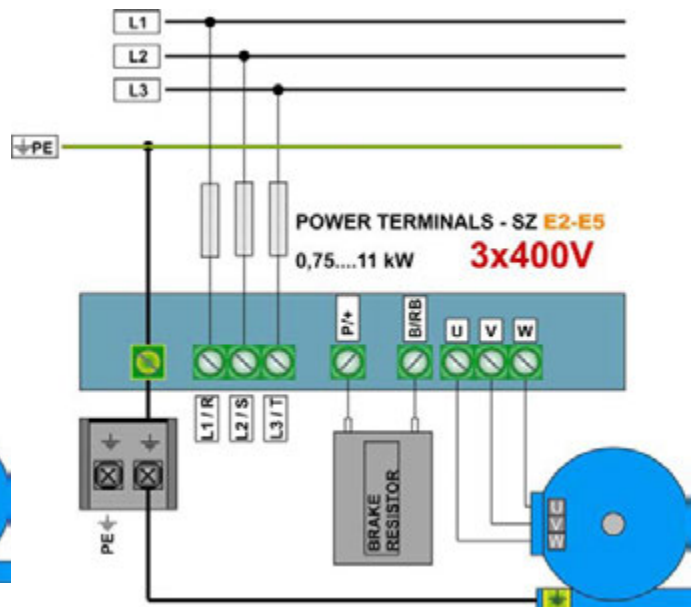
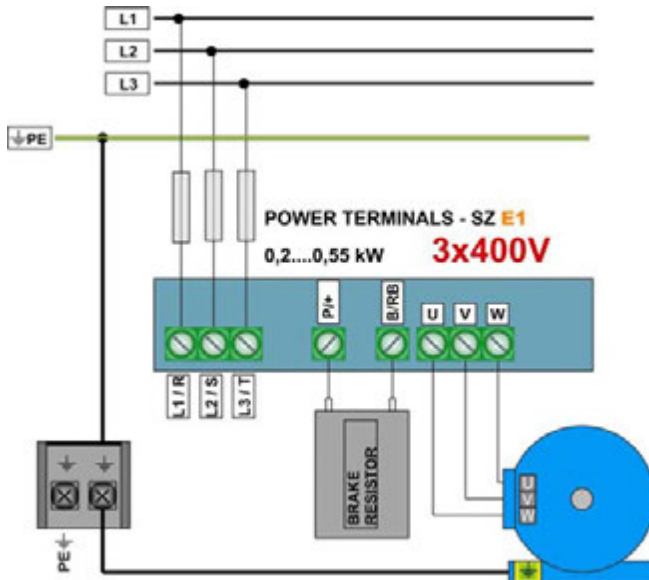

15 – 22 kW – Framesize E6

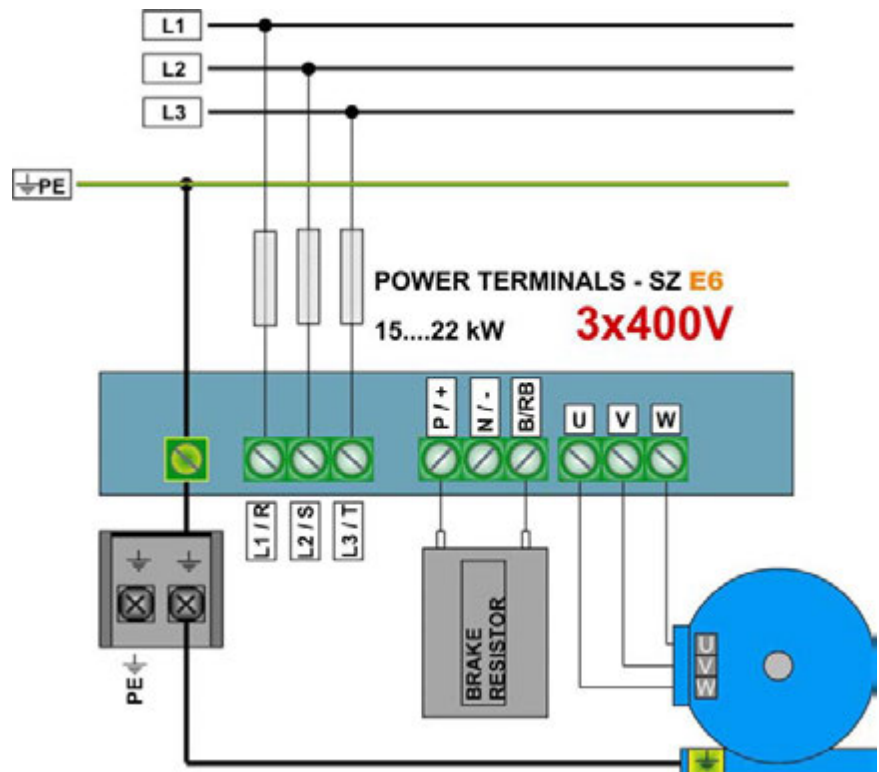

4) Electrical wiring of E800 inverters

400V Threephase above 30 kW C3.....C6

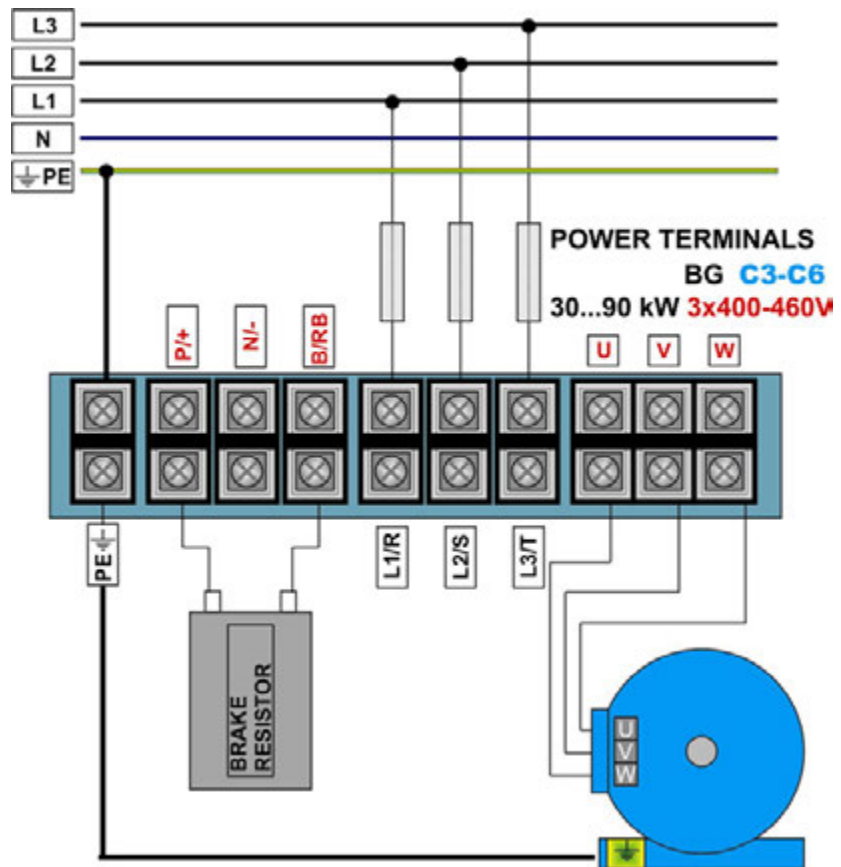

Brake resistor:

E800 inverters have built in chopper transistor as standard. An adequate brake resistor can be connected externally. The maximum cable length is 2mt, the cross-section depends on the current through the resistor, calculated, considering the brake switch on voltage of 800V and the resistor value.

The minimum resistor value for single inverter power ranges is reported in table on chapter: 2) *Product overview / Product data* – the value in the table is the absolute minimum value – resistors with up to three times higher resistance value are allowed.

Right dimensioning of the resistor, especially in sense of continuous power and peak power depends on the application (inertia, speed, brake cycle rate).

EURADRIVES accessories program offers special resistors for all kind of application.



ATTENTION!! All stored dynamic energy of the system is converted in heat, during the brake process - heat, dissipated in the brake resistor. Overheating of the resistor, risk of burning and fire may be the consequence of improper dimensioning, wrong parameter setting, inverter fault or power supply over-voltage.

It is necessary to provide suitable electrical and mechanical protection of the brake resistor

The rules in chapter 1) *Common installation and safety rules* are to observe. EURADRIVES does not take any responsibility for any damage or risk, if improper brake resistors are used.

4) Electrical wiring of E800 inverters

Recommended cable cross sections, fuses, terminal tightening torque

Modell	Input current	Cable cross section (mm ² AWG) Terminal tightening torque	Input fuses		
			IEC 60269 gG (A)	UL-Class T (A)	Busmann-Type
	A	mm² / AWG / lbs/inch			
E800-0007 T3	2,4	2,5 / AWG14 /10	10A	10A	JJS10
E800-0015 T3	4,6				
E800-0022 T3	7				
E800-0030 T3	9				
E800-0040 T3	11	2,5 / AWG12 /10,5	16A	15A	JJS15
E800-0055 T3	16	4 / AWG10 /19	25A	20A	JJS20
E800-0075 T3	20			30A	JJS30
E800-0110 T3	29			6 AWG8 /30,4	35A
E800-0150 T3	37	10 AWG6 /30,4	50A	40A	JJS40
E800-0185 T3	45	16		50A	JJS50
E800-0220 T3	54	16	63A	60A	JJS60
E800-0300 T3	72	25	80A	80A	JJS80
E800-0370 T3	85	35	125A	90A	JJS90
E800-0450 T3	110	35		125A	JJS125
E800-0550 T3	132	50	160A	175A	JJS175
E800-0750 T3	180	95	200A	200A	JJS200
E800-0900 T3	220	120	250A	250A	JJS250
Steuerleitungen alle Framesizen		0,75-1 AWG20 /2,7			

Earth/ground connection

Minimum earth/ground wiring cross section – for terminal connection

Motor wiring section: S (mm ²)	Minimum earth wiring cross section \neq /PE/E (mm ²)
S ≤ 16	= S
16 < S ≤ 35	min 16
35 < S	Min S/2

Minimum earth/ground wiring cross section – for chassis connection (on designed "G" "GND" "GROUND" connection points)

Motor wiring section: S (mm ²)	Minimum earth wiring cross section \neq /PE/E (mm ²)
S ≤ 16	= S AWG8 / 6,2

4) Electrical wiring of E800 inverters

Control terminals – control board

Two different configurations of control terminals and control boards are available, depending on inverter frame size

Inverter Size E1 – E6
0,20....22 kW

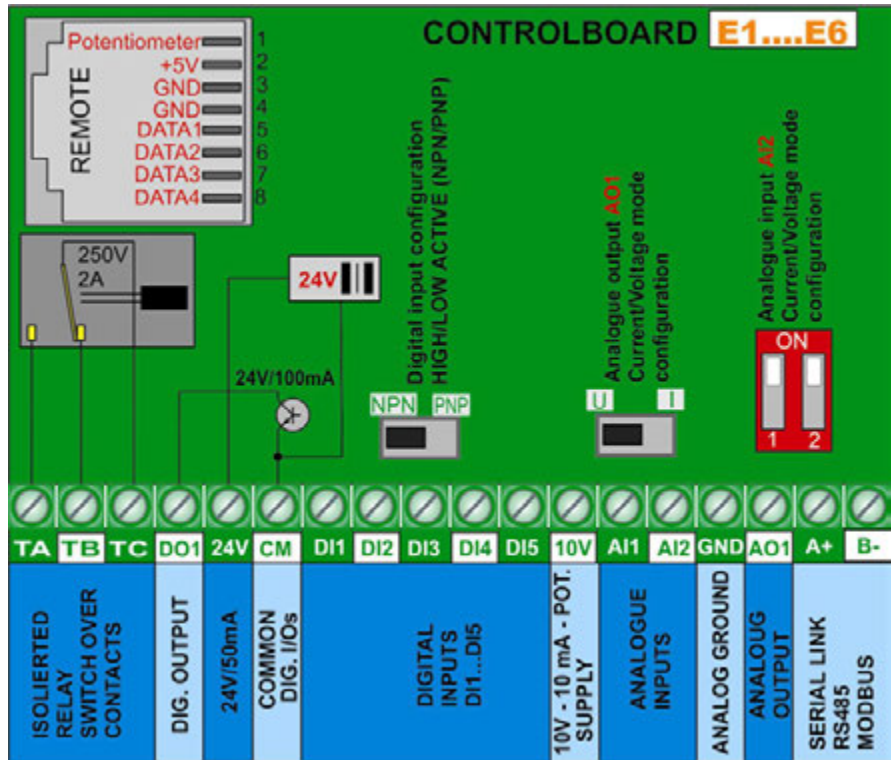

Inverter Size C3 – C6
30....90 kW

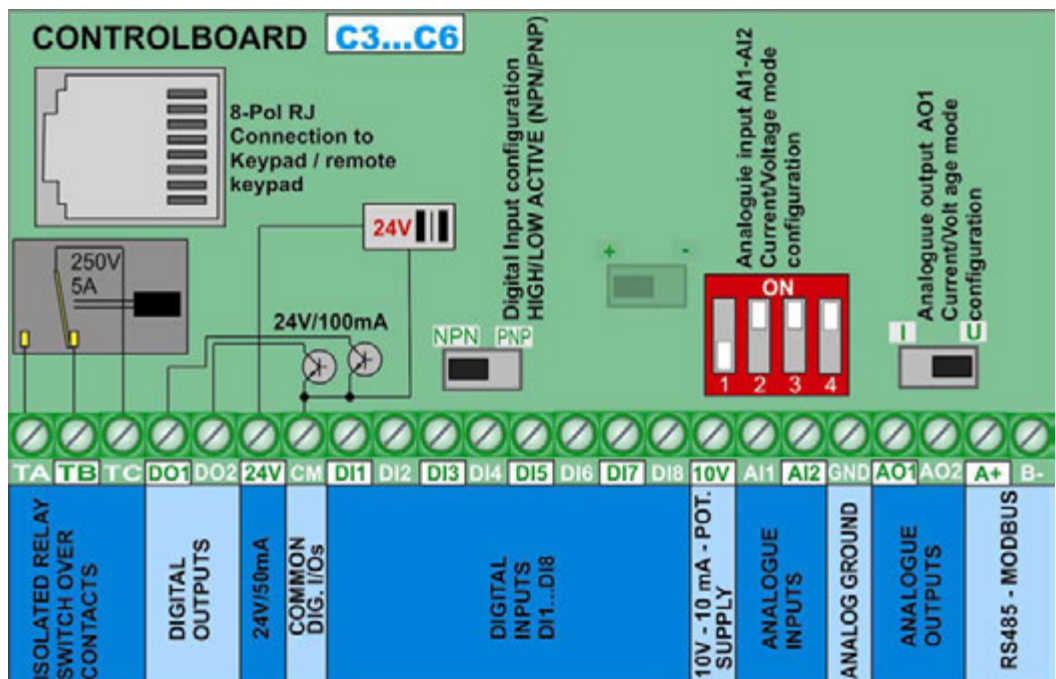

Control terminal function and factory default configuration

Terminal	Type	Description	Hardware data	Related parameter	Factory DEFAULT
DO1	Digital / analogue OUTPUTS	Programmable digital output 1	Open-Collector output, max. 100mA-24V (referred on CM)	(F301)	Message F=>0Hz
DO2		Programmierbarer Digitalausgang 2	Open-Coll. output max. 100 mA-24V (referred to CM (Size C3-C6 only))	(F302)	Message F>0HZ
TA TB TC		Digital Relays output - isolated switchover contact	TC=COMMON TB=NORMAL CLOSED TA=NORMAL OPEN Max. Contact load: Inverter 22kw and below: 2A/230VAC Inverter above 22 kW: 5A/230V	(F300)	Fault signal
AO1		Programmable analogue output 1	To configure for voltage/current signal (reference: analogue ground GND) For current signal: set SWITCH to „I“	(F413---F426) (F431)	Output frequency 0...10V
AO2		Programmable analogue output 2	Current signal (referred on GND) (on size C3-C6 only)	(F427----F430) (F432)	Motor current 0-20mA
10V	DC 10V	10V, ref. to processor- GND	10V supply for potentiometer or similar, max. current 20 mA		
AI1	Analogue inputs 12 BIT	Programmable analogue input 1	Set-point – current/voltage input for configuration see: (<i>Hardware-configuration of I/O channels</i>)	(F400-F405) (F418)	0...10V
AI2		Programmable analogue input 2		(F406-F411) (F419)	0..20 mA
GND		Analogue GROUND	Microprocessor ground, reference point for all analogue signals		
24V	DC 24V	Isolated 24V power supply	24±1.5V, to CM; limited to 50mA, for powering of digital I/Os		
DI1	Programmable digital inputs	Programmable digital input 1	All digital I/O are floating, including 24V and CM HIGH/LOW active, hardwaremäßig umschaltbar (<i>siehe: Hardware und Hardware-Konfiguration der I/O Kanäle.</i>) (DI6-DI8 on size C3-C6 only)	(F316)	JOG mode FWD
DI2		Programmable digital input 2		(F317)	EMERGENCY STOP external
DI3		Programmable digital input 3		(F318)	Terminal (FWD)
DI4		Programmable digital input 4		(F319)	Terminal (REV)
DI5		Programmable digital input 5		(F320)	RESET
DI6		Programmable digital input 6		(F321)	Power stage enable
DI7		Programmable digital input 7		(F322)	START
DI8		Programmable digital input 8		(F323)	STOP
CM	COMM	Common potential digital I/O	Common terminal for 24V aux. supply – digital I/O signals		
A+	RS 485	Differential signal, positive	Standard: TIA/EIA-485(RS-485) Interface protokol: MODBUS Bd.Rate: 1200/2400/4800/9600/19200/38400/57600	(F900-F905)	9600
B-		Differential signal, negative			

Sample set-up for inverter, 400V - framesize E6

If parameter status is unknown, factory reset is recommended: Set parameter **F160 = 1**

Analogue speed reference 0...10V (potentiometer) through input channel **A11**: Set **F203=1**
 START/STOP command and inversion through terminal signals: set **F208=2** (two wire control)
 Fault signalling on relays contact: **F300=1** (already default set)
 „Inverter enabled“ message on **DO1** **F301=14** (already default set)
 Frequency indication output: **AO1** 0...10V = 0-50 Hz **F423=1**, **F431=0** (already default set)

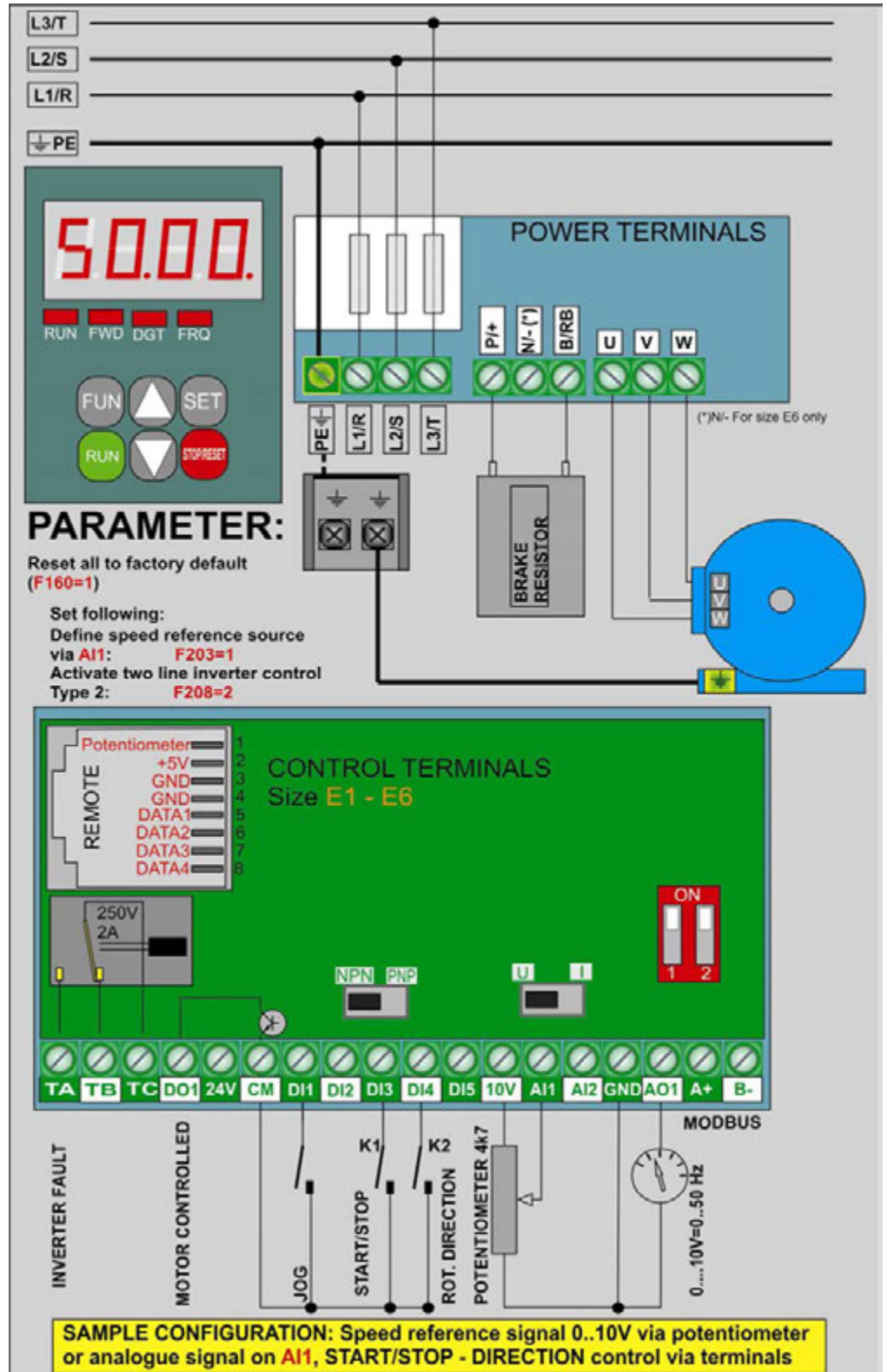

5) Control-board: hardware and I/O channel configuration

I/O channel configuration is a combination of hardware and software setting

For software parameter setting see chapter:

10) Parameter group 300: Configuration of digital I/O channels

11) Parameter group 400: Configuration of analogue I/O channels

Two different type of control boards are used in E800 inverter concept:

Control board for inverter 0,2 - 22 kW: Framesize E1 - E6

Control board for inverter 30kW - 90 kW: Framesize C3 - C6

Control board
0,2...22kW
SZ E1 - E6:

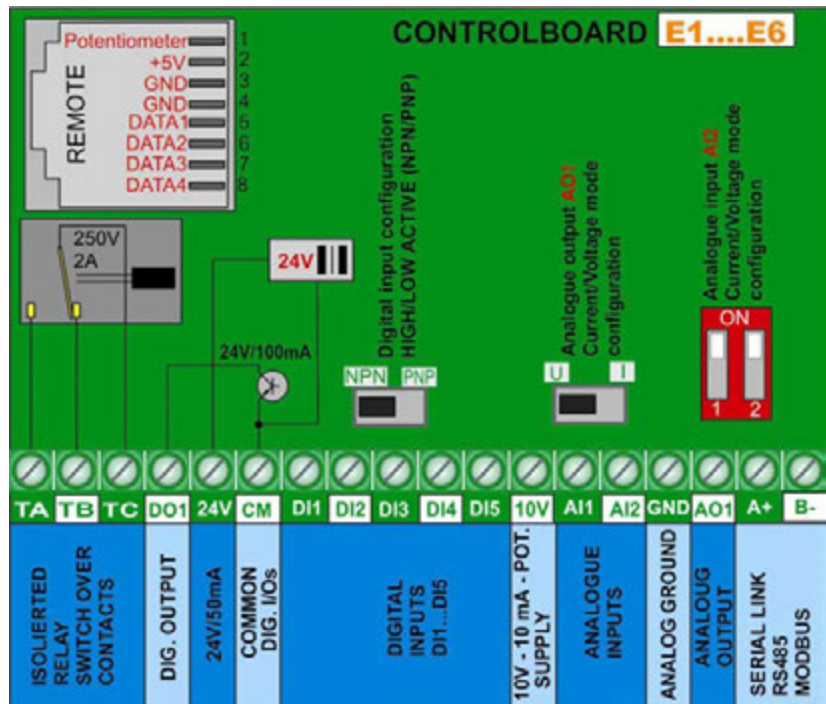

Digital input channels: E1 - E6:

A total of 5 digital input channels DI1.....DI5 are available on inverter, size E1-E6. Different functions can be assigned to these inputs, programming the parameter F316....F320 – description: see chapter 10) Parameter group 300: Configuration of digital I/O channels

Attention: A function can be assigned to one single digital input only (no multiple inputs for same function allowed) If a function is already assigned to a certain input (due to factory set), this assignment must be deleted (set function-code to 0), before assigning to another input.

HIGH/LOW active (PNP/NPN) control-mode selection: This selection is done via hardware setting of the NPN-PNP DIP-SWITCH on the control board.

All digital inputs are isolated from analogue ground, the 24 V (50mA) auxiliary power supply may be used for input control in PNP mode. CM is the common reference point for all digital inputs.

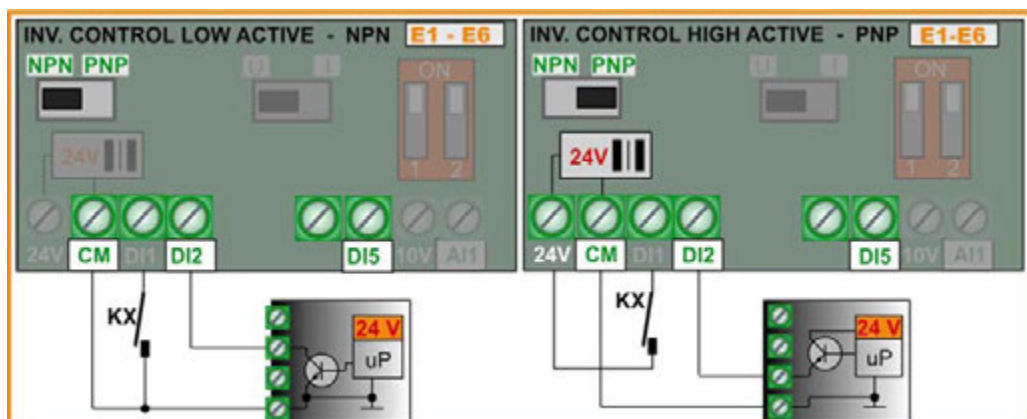

Analogue input channels: E1 - E6:

E800 SIZE E1...E6 have two independent analogue input channels AI1 and AI2, both have a resolution of 12 Bit. Signal level configuration is done by hardware setting on the control board, and corresponding parameter setting.

For software parameter setting see: 11) Parameter group 400: Configuration of analogue I/O channels

AI1 Voltage signal input: 0...10V

AI2 Voltage/Current signal input: to configure for 0...5V, 0...10V or 0...20 mA - (4...20 mA: offset, to set via software parameter – F406, F408) – (factory-default setting 0...20 mA)

Configuration of AI2

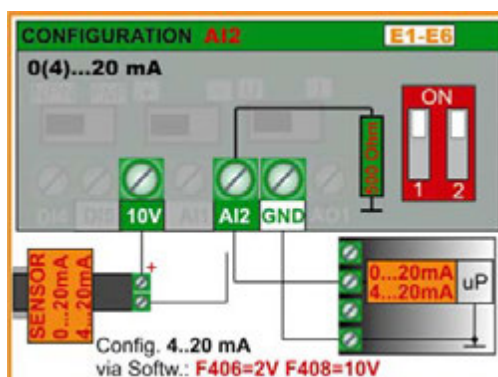
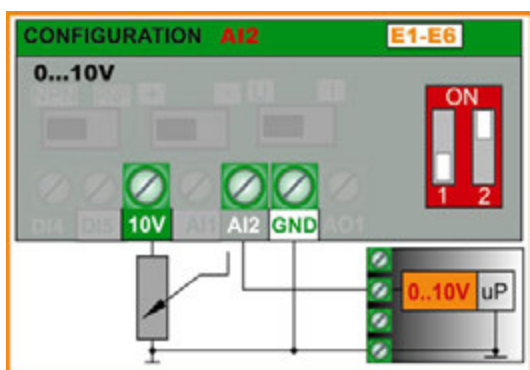

Input impedance with voltage signal: 10 kOhm
 Apparent ohmic resistance with current control: 500 Ohm

Digital output channels: E1 - E6:

Inverters of the E800 series, SIZE E1...E6 have one relay contact output, and one open collector output DO1, both are free programmable for different functions, assignment codes are set in parameters F300 – F301.

TA-TB-TC Relay output: isolated switch over contacts, max. contact-load: 2A 230V (F300)

DO1 Digital output: OPEN COLLECTOR, referred to CM - U/High=24V, max. sink-current 100mA. (F301)

Analogue output channels: E1 - E6:

One analogue output channels is available on inverters E800 SIZE E1-E6: AO1. Different functions can be mapped to this channels

AO1 : To configure for **voltage** or **current** signal – function assignation code in parameter F431

Software parameter F423...F426, for signal type configuration – see chapter: *Parameter group 400*

Hardware setting for AO1 only (voltage/current signal selection):

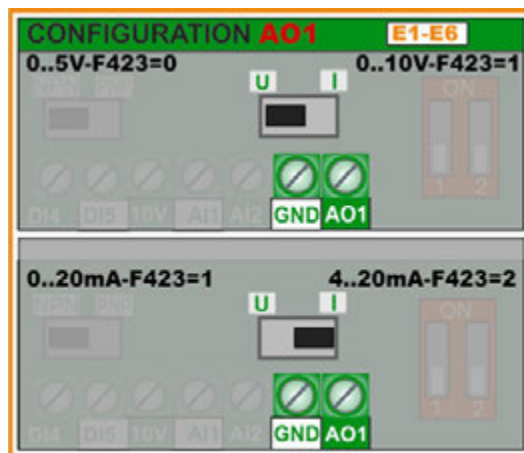

Control-board inverter
30...90kW
 SZ C3 – C6:

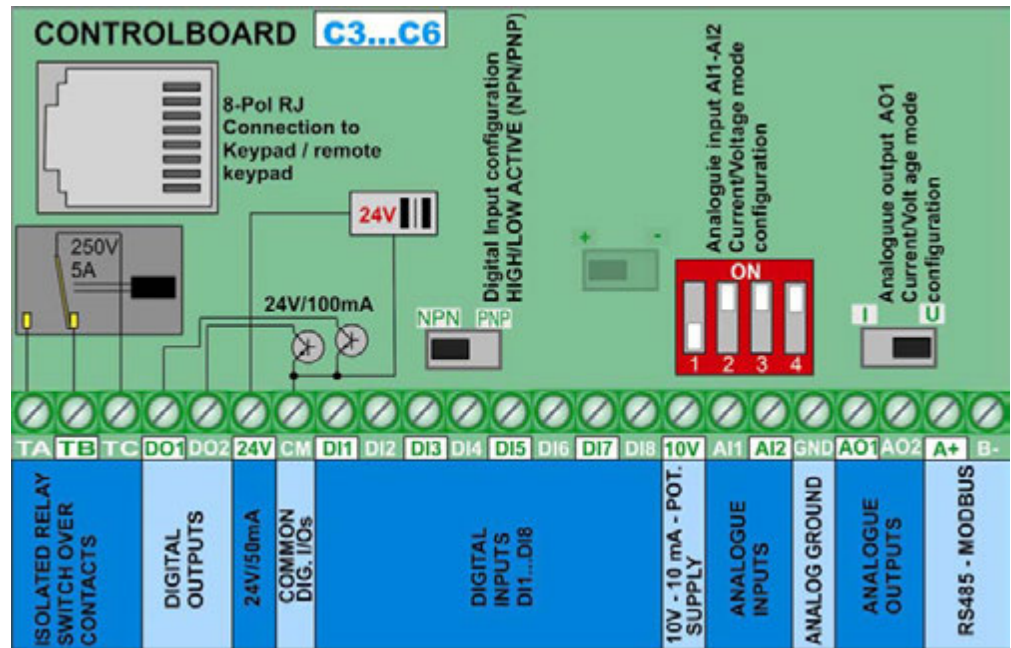

Digital input channels: C3 – C6:

A total of 8 digital input channels DI1.....DI8 are available on inverter, size C3-C9. Different functions can be assigned to these inputs, programming the parameter F316.....F323 – description: see chapter 10) *Parameter group 300: Configuration of digital I/O channels*

Attention: A function can be assigned to one single digital input only (no multiple inputs for same function allowed) If a function is already assigned to a certain input (due to factory set), this assignment must be deleted (set function-code 0), before assigning to another input.

HIGH/LOW active (PNP/NPN) control-mode selection: This selection is done via hardware setting of the **NPN-PNP DIP-SWITCH** on the control board.
 All digital inputs are isolated from analogue ground, the **24 V (50mA)** auxiliary power supply may be used for input control in PNP mode. **CM** is the common reference point for all digital inputs.

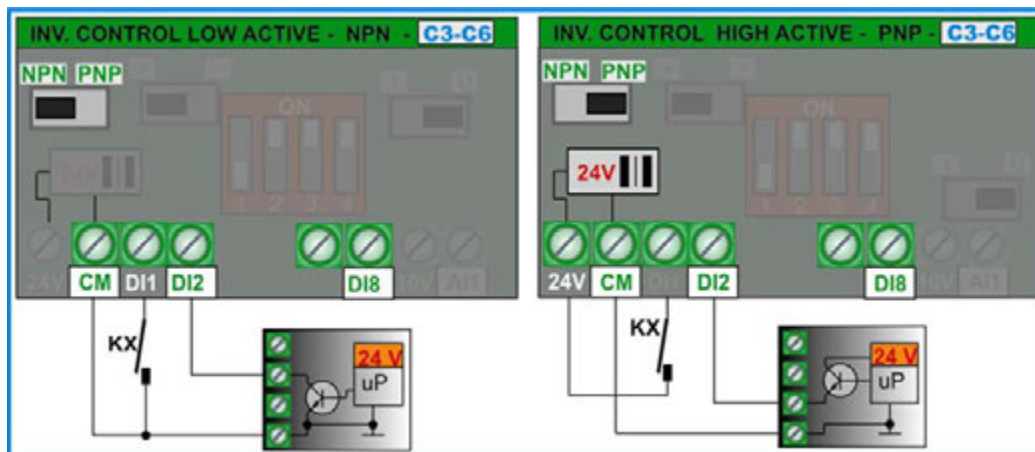

Analogue input channels: C3 – C6:

E800 SIZE C3...C9 have two independent analogue input channels AI1 and AI2, both have a resolution of 12 Bit. Signal level configuration is done by hardware setting on the control board, and corresponding parameter setting

For software parameter setting see: 11) *Parameter group 400: Configuration of analogue I/O channels*

AI1 – Voltage / Current signal: programmable for 0...5V, 0...10V, 0...20 mA. For 4...20 mA: offset, to set via software parameter F400, F402 - (factory-default setting 0...10V)

AI2 Voltage/Current signal input: to configure for 0...5V, 0...10V or 0...20 mA – For 4...20 mA: offset, to set via software parameter – F406, F408 – (factory-default setting 0...20 mA)

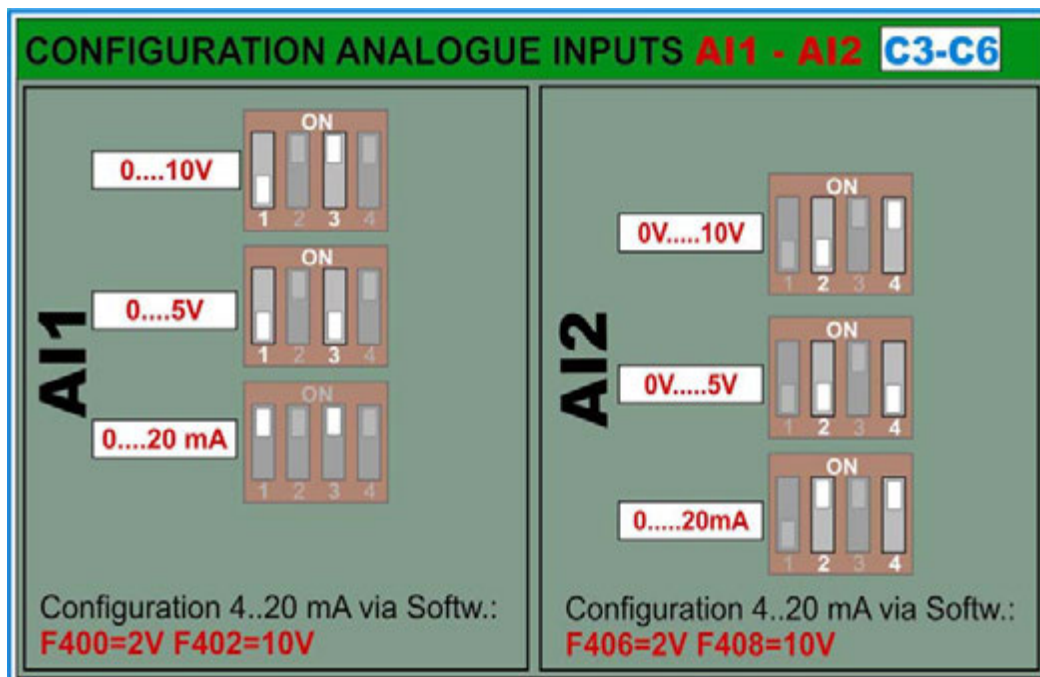

Input impedance with voltage signal: 10 kOhm

Apparent ohmic resistance with current control: 500 Ohm

Digital output channels: C3 – C6:

Inverters of the E800 series, SIZE C3...C6 have one relay contact output, and two open collector output DO1 and DO2, both are free programmable for different functions, assignation codes are set in parameters F300 – F302.

TA-TB-TC Relay output: isolated switch over contacts, max. contact-load: 5A 230V (F300)

DO1 Digital output: OPEN COLLECTOR, referred to CM - U/High=24V, max. sink-current 100mA. (F301)
DO1 may work as fast pulse signal output too, set via parameter F303 max. frequency 50 kHz, U_{ss}=24V

DO2 Digital output: OPEN COLLECTOR, referred to CM - U/High=24V, max. sink-current 100mA (F302).

Analogue output channels: C3 – C6:

Two analogue output channels are available on inverters E800 SIZE C3-C6: AO1 and AO2. Different functions can be mapped to both channels

AO1 : To configure via hardware for **voltage** or **current** signal mode – signal configuration via parameter 423-426, function assignation code in parameter F431

Hardware configuration is necessary for AO1 only (voltage/current mode selection)

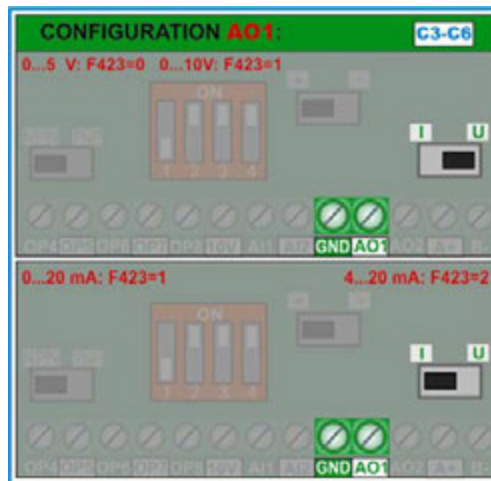

AO2 : Output for **current** signal only – function assignation code: F432

Motor protection with PTC/KLIXON: Valid for all inverter size E1 - E6 and C3 – C6

For simple applications and short motor cables (<5m) the digital inputs OP1...OP6 (8) can be used as PTC/NTC/KLIXON signal input channel.

For hardware set-up, see picture below, the value of the resistor depends on the PTC value, if KLIXON is used for motor protection, a 1 kOhm resistor, 1 WATT is recommended. Each digital input is programmable for PTC/KLIXON signal evaluation

The trigger threshold is about 4 V – it means about 20V input signal level for PNP configuration - about 4V input signal level for NPN configuration.

If triggered, OH1 is the error code shown on the display

Function assignation parameter F316...F323:
code: 37 for normal open contact (NTC)
code: 37 for normal closed contact (PTC)

ATTENTION!!! Provide adequate insulation between PTC/KLIXON circuit and motor phases

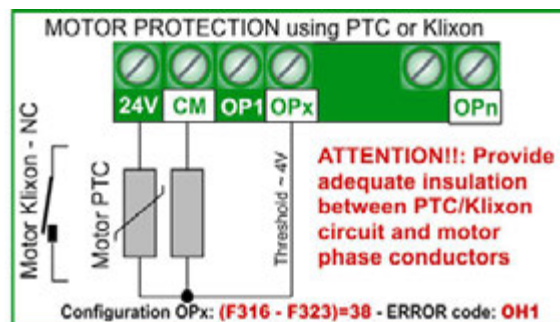

6) Operating panel

Inverter control, parametrization, operating-parameter display and inverter-status information are all done through the operation panel. This consists in seven segment, 4-digit display, six button keypad field and 4-LED status line.

The adjacent picture shows the standard version: 7-segment display, status LED and keypads

An optional build-in potentiometer is available

7-segment display:

The content of the display can be configured, to show different operating parameters, while inverter in STOP or START mode, error messages, parameters and parameter values (for configuration see chapter: Parameter group 100 – BASIC parameter)





The **FUN** key is used to cycle through all programmed content, including configuration parameter level. (Configuration parameter on display have always a leading *F*).

Faults are displayed with the respective error code.

Flashing numbers in STOP mode indicate the target-frequency, which the inverter will reach after START command is given.



Status LED: To display the inverter status:

			
Inverter in START mode. The display shows the programmed working parameters	To indicate the rotating direction	Toggle with  key ON: single step modus is selected for parameter cycling OFF:parameter group cycling	ON, if the value on the display corresponds to output frequency

Keys and functions

				
Cycling through different display content	START command	STOP command Toggle switch for  ERROR RESET	Parameter: Selection, and save	Increment / Decrement Key

Display of function parameters and error codes

DISPLAY	DESCRIPTION
HF-0	Anzeige TIP Betrieb
-HF-	RESET, POWER-ON Prozess
O.C. OC1 O.L1 O.L2 O.E. P.F1. PF0 L.U. O.H. OH1 CE FL AErr nP ERR1 ERR2 ERR3 ERR4 ERR5 ERR6	ERROR codes, description see chapter (<i>Parameter group 700: Error handling and protection functions</i>)
ESP	External EMERGENCY STOP has been triggered
F152	The leading <i>F</i> displays configuration parameter number (Parameter Nr. 152)
10.00	Output frequency (if FRQ=ON), operating parameter, configuration parameter value
50.00	Flashing numbers in STOP mode: Target frequency/speed after START command is given
0.	Dead band during rotation direction change
A100 U100, b*.*, o*.*y, L*.*;H*.*	Operating parameters in START / STOP mode: Motor current, Motor voltage, DC-voltage, Temperature PID-controller feed-back value.....for programming: see parameter <i>F131 – F132</i>

Remote operating panel

Inverter 0,2...22kW – Size E1-E6: The display is integrated in the control board, the keypad is part of the inverter-cover. The optional remote keypad is connected through the lateral MODBUS connector, using standard 4 pole RJ plug (telephone style). Remote unit ordering code: **A6-1-A (Parametrierung: F421=1, F901=3)**

Inverter 30...90kW – Size C3-C6: The keypad/display unit is removable, connection to the control-board is made via 8 pole cable. An optional mounting frame for the remote unit is available as option. Standard LAN cable (8 pole) can be used for remote connection.

7) Parametrization

For easier parametrization, the parameter set is divided into 11 parameter groups:





Parameter type	Parameter Nr. Range	Gruppe
BASIC parameters	F100 - F160	100
Inverter control, set-point origin setup	F200 - F230	200
Function assignment to digital I/Os - diagnosis	F300 - F330	300
Analogue I/O signal configuration	F400 - F473	400
Fixed-frequency control, cycle control	F500 - F572	500
DC-Brake, limiting functions, auxiliary functions	F600 - F623	600
Fault handling – configuration of protection function	F700 - F740	700
Motorparameter, AUTOTUNING	F800 - F830	800
Serial link parameter set	F900 - F930	900
PID controller parameter, pump control functions	FA00 - FA30	A00



Selection of parameters, modification and saving:

The **FUN** key toggles between all different values on the display.

F prefix indicates parameter level and the number refers to a configuring parameter.

Once on parameter level, the   keys are used to flip through parameters.

 key toggles between single and multi parameter step. If  is on, single mode is selected, if off, group mode is selected, and   keys moves in steps of 100.

SET key selects the parameter on the display, and the parameter value is shown. The blinking digit may be changed, using   keys (eventually use  key to switch through single digits). Pressing **SET** again memorizes the modified parameter value.

Parameter types:

Read only parameters: These parameters can not be changed, the tentative to modify will end up in **Err1** message – read-only parameters are listed in **GRAY characters**

Dynamic parameters: These parameters are allowed to modify with inverter in **START** and in **STOP** mode, listed in red bold characters on this description: **Fxxx**

Static parameters: To modify with inverter in **STOP** mode only, otherwise, **Err1** is displayed, static parameters are listed in red, italic bold characters as *Fxxx*

8) Parameter group 100: Basic parameters

F100 Password	Range: 0 – 9999	Werkspasswort: 8
----------------------	-----------------	------------------

-If F107=1 (password enabled): enter correct password, to unlock parameter modification function. Incorrect password results in **Err1** on the display

F102 Rated inverter current (A)	Range: 1.0 – 800.0	Factory set, depending on model, read only
F103 Rated inverter power (KW)	Range: 0.2 – 800.0	Factory set, depending on model, read only

F105 Software Version No.	Range: 1.00 - 10.00	Factory set, depending on model, read only (2.04)
----------------------------------	---------------------	---

F106 Control algorithym	Selection: 2: V/Hz 3: Reserved 4: Reserved 5: Reserved 6: Synchronous motor control *	Default setting: 2
--------------------------------	---	--------------------

2: V/Hz Modus funktioniert auch bei mehreren parallel geschalteten Motoren

6: * Optional software for synchronous motor control (permanent magnet motor)

Attention!!

All motor parameters must be set precisely, to guarantee correct function. Especially in synchronous motor control mode (F106=6) we recommend to run the AUTOTUNING routine (see: parameter group 800)

The V/Hz mode is recommendet for simple drives, including applications with quadratic torque characteristic (pump – fan). F137 defines the different V/Hz characteristics
 Inverter rated power should match the motor power

F107 Activation of password protection (for parametrizing)	Selection: 0: No password protection 1: Password protection	Default setting: 0
F108 Password setting	Range: 0 - 9999	Default setting: 8

F109 Start – frequency (Hz)	Range: 0.00 - 10.00 Hz	Default setting: 0.00 Hz
F110 Start – frequency duration (sec.)	Range: 0.0 - 10.0 sec.	Default setting: 0.0 sec.

The inverter always starts running with the selected Start-frequency, if the target frequency is lower than the Start-frequency, **F109** will be ignored.

After the inverter gets a START command, it will remain at the Start-frequency, (set in **F110**), for the time, set in **F111**. After the delay, it will proceed with the acceleration ramp to reach the final frequency. The acceleration ramp does not take into account the start frequency delay time

The Start-frequency value is independent and not limited by the minimum frequency **F112**. In case **F109** is lower, than **F112**, the inverter will start running with the values in **F109** and **F110**. After the inverter reached the minimum frequency **F112**, the values **F111** and **F112** are considered as frequency limits.

It is recommended, to chose Start-frequency lower than maximum frequency (**F111**).

F111 Maximum frequency (Hz)	Range: F113 - 650.0 Hz	Default setting: 50.00Hz
F112 Minimum working frequency (Hz)	Range: 0.00 - F113 Hz	Default setting: 0.50Hz

The parameter **F111** limits the inverter output frequency

In SENSORLESS VECTOR mode it is recommended to limit the maximum frequency to 150 Hz

The parameter **F112** defines the minimum allowed output frequency. If speed reference corresponds to frequency lower than the value in **F112**, the inverter stops.



WARNING!! Continuous operation at low speed may overheat the motor – forced ventilation is recommend

8) Parameter group 100: Basic parameters

F113 Internal speed reference (Hz)	Range: F112 - F111	Default setting: 50.00 Hz
---	---------------------------	----------------------------------

Virtual internal speed reference, it is selectable in the same way, as any external speed reference (see F203, F204). If selected, after the START command, the inverter will reach this speed value.

F114 Acceleration ramp 1 (sec.)	Range: 0.1 – 3000 sec.	Default setting: 0.2 - 3.7KW, 5.0 sec. 5.5 - 30KW, 30.0 sec. > 37KW, 60.0 sec.
F115 Deceleration ramp 1 (sec.)		
F116 Acceleration ramp 2 (sec.)		Default setting: 0.2 - 3.7KW, 5.0 sec. 5.5 - 30KW, 30.0 sec. > 37KW, 60.0 sec.
F117 Deceleration ramp 2 (sec.)		

Acceleration ramp: Time to reach 50 Hz, or F-max (it depends on F119)

Deceleration ramp: Time, to decelerate to 0 Hz, referred to 50 Hz, or F-max (depending on F119)

The second ramp set is selectable via programmable digital input (OP1..OP8) - (F316~F323).

F119 Reference for Accel./Decel. ramp time	Selection: 0: 0 ... 50.00Hz 1: 0 ... F-max	Default setting: 0
---	---	---------------------------

If F119=0, ramp time is the duration from 0 Hz to 50 Hz, If F119=1 it is from 0 Hz to F-max.

F118 Knee frequency (Hz)	Range: 15.00 - 650.0	Default setting: 50.00Hz
---------------------------------	-----------------------------	---------------------------------

Frequency, corresponding to the maximum inverter output voltage, the U/F characteristics reaches the horizontal range

Below the knee-frequency, the drive system operates in constant torque, above it works with constant power



ATTENTION!! Wrong setting of the Knee-Frequency may destroy the motor

F120 Dead time during reversion (sec.)	Range: 0.0 – 3000 sec.	Default setting: 0.00 sec.
---	-------------------------------	-----------------------------------

If activated (>0), the inverter will stop at 0Hz during the reversing cycle, indicated as 0. on the display. (these parameter has no effect, if automatic frequency cycling is chosen).

This function may be useful, to avoid torque/current peaks during reversion

F122 Reverse operation disable	Selection: 0: reversion enabled 1: reversion disabled	Default setting: 0
---------------------------------------	--	---------------------------

If F122=1 the inverter can operate in one rotating direction only, regardless of different other settings or control signals. A reversing command will result in inverter STOP

If inverter rotation is set to "reverse" by parameter (F202=1), and F122 is set to "reversing disable", the inverter will not start

If "Catch on the fly" function is active, it will catch the motor, beginning with 0.0 Hz



F123 Reversing enable with combined speed control	Selection: 0: disable 1: enable	Default setting: 0
--	--	---------------------------

If in case of combined speed control, the speed result becomes negative (reverse rotation), this function may be used to enable/disable the reverse rotation of the motor. If disabled, in case of negative speed, the inverter output 0,0 Hz (Parameter F122=1 overwrites this setting)

8) Parameter group 100: Basic parameters

F124 Jog frequency (Hz)	Range: F112 - F111	Default setting: 5.00 Hz
F125 Accel. ramp – Jog Mode (sec.)	Range: 0.1 – 3000 sec.	Default setting: 0.2 - 3.7KW: 5.0 sec. 5.5 - 30KW: 30.0 sec. > 37KW: 60.0 sec.
F126 Decel. ramp –Jog Mode (sec.)		

There are two modes to activate the Jog frequency: Keypad-control, and terminal-control (programmable digital inputs OP1...OP8 – configuration: F316...F323).

Keypad-control: With the inverter in STOP mode press  key, to display HF-0, in this condition the  key works as a Jog frequency start/stop toggle (F132 must be configured in the proper way 1+x+x+x).

Terminal control: A proper configured digital input works as Jog frequency start/stop toggle

Remark: In Jog mode the "catch on the fly" function is deactivated

F127/F129 Cut-Off frequency A,B (Hz)	Range: 0.00 - 650.0	Default setting: 0.00 Hz
F128/F130 Cut-Off frequency window A,B (Hz)	Range: ±2.5 Hz	Default setting: 0.0 Hz

Cut-Off frequency to avoid resonance problems – the inverter transits during accel. / decel. ramps through this frequency areas, but it can not stay stable within this frequency ranges.

Display configuration:

F131 Display: Selection of operating parameters to display during „START“ status (Motor running)	0: Output frequency / parameter value	Default setting: 0+1+2+4+8=15 (frequency+speed+motor-voltage+motor-current+DC-voltage)
	1: Motor speed (rpm)	
	2: Motor current	
	4: Motor voltage	
	8: DC-voltage	
	16: PID control feed back	
	32: Heatsink temperature	
	64: Reserviert	
	128: Speed (linear - calculated)	
	256: PID set-point	
	512:	
	1024:	
2048:		
4096:		
8192:		

To display a specific parameter, just set Parameter F131 to one of the values in the table above, to display more parameters, the sum of all values must be set in F131

The  key is used to cycle through the various selected parameter values

8) Parameter group 100: Basic parameters

<p>F132 Display: Selection of operating parameters to display during „STOP“ status (Motor stopped)</p>	<p>0: Target frequency / Parameter (Fxx) 1: Jog modus via keypad - HF-0 2: Target motor speed (rpm) 4: DC-voltage 8: PID control feed back 16: Heatsink temperature 32: Reserved 64: PID Set point 128: Reserved 256: Reserved 512: Reserved 1024: Reserved 2048: Reserved</p>	<p>Default setting: 0+2+4=6</p>
---	--	--

With inverter in STOP mode, the display will always show the target frequency - flashing

Following table shows the units and display-mode for various parameters:

- Motorspeed (rpm): **(NNNN)** integer value – the decimal point indicates values above 9999.
- Motor Current **A (A.A)**
- Motor-Voltage: **U (VVV)**
- Counter status: **(ZZZZ)**
- DC-Voltage: **u (VVV)**
- Heatsink temperature: **H (TTT)**
- Calculated speed **L(sss)**. Decimal point to indicate values above 999, two decimal points for values above 9999
- PID controller Set-Point (normalized): **(o*.)**
- PID Feed-Back (normalized): **(b *.*)**

Single phase inverter size E1 (0.2 - 0.75KW) do not have temperature indication.

Parameter, for calculated speed indication (display)

<p>F133 Transmission ratio</p>	<p>Range: 0.10 - 200.0</p>	<p>Default setting: 1.00</p>
<p>F134 Pulley diameter</p>	<p>0.001 – 1.000 (m)</p>	<p>Default setting: 0.001</p>

-Example: Max. Frequency **F111=50.00Hz**, number of poles **F804=4**, transmission ration **F133=1.00**, pulley diameter R=0.05m (**F134=0,05**), calculation result: pulley circumference: $2\pi r = 2 \times 3.14 \times 0.05 = 0.314$ (meter), shaft speed: $60 \times \text{frequency} / (\text{number of poles} \times \text{transmission ratio}) = 60 \times 50 / (2 \times 1.00) = 1500 \text{rpm}$. For linear speed: $\text{speed (rpm)} \times \text{pulley circumference} = 1500 \times 0.314 = 471 \text{(meter/second)}$

8) Parameter group 100: Basic parameters

F136 Slip compensation in V/Hz mode	Range: 0 - 10%	Default setting: 0
--	-----------------------	---------------------------

- This parameter compensates the load-depending slip of the asynchronous motor – it works only in the stable area of the motor speed/torque characteristic
- during the "catch on the fly" process this function is deactivated

F137 Motor voltage increase in the low frequency range (for V/Hz mode only)	Selection: 0: Linear 1: Quadratic 2: User defined (6 - Point) 3: Automatic	Default setting: 3
F138 Lineare increase	Range: 1 - 20	Werk: 0.2-3.7 kW : 7 5.5-30 kW : 6 37-75 kW : 5 > 90 kW: 3
F139 Quadratic increase	Selection: 1 - 6	Default setting: 1

Voltage increase on low frequencies is necessary to compensate the stator copper resistance.

With **F137=0 linear** voltage increase is chosen, suitable for constant torque load.

F137=1 quadratic increase, the right curve for load with quadratic characteristic, like pump and fan.

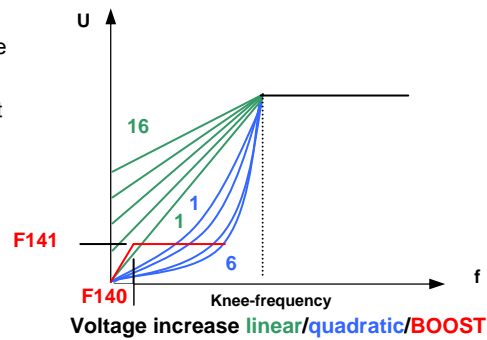

F137=2, serves to possible to program a user specific V/Hz curve – see table below

A total of 12 parameter are necessary to define the user specific curve (**F140 bis F151**).

F140 User defined frequency F1	Range: 0 - F142	Default setting: 1.00
F141 Assigned motor voltage V1	Range: 0 - 100%	Default setting: 4
F142 User defined frequency F2	Range:F140 - F144	Default setting: 5.00
F143 Assigned motor voltage V2	Range: 0 - 100%	Default setting: 13
F144 User defined frequency F3	Range: F142 - F146	Default setting: 10.00
F145 Assigned motor voltage V3	Range: 0 - 100%	Default setting: 24
F146 User defined frequency F4	Range: F144 - F148	Default setting: 20.00
F147 Assigned motor voltage V4	Range: 0 - 100%	Default setting: 45
F148 User defined frequency F5	Range: F146 - F150	Default setting: 30.00
F149 Assigned motor voltage V5	Range: 0 -100%	Default setting: 63
F150 User defined frequency F6	Range: F148 - F118	Default setting: 40.00
F151 Assigned motor voltage V6	Range: 0 - 100%	Default setting: 81

Remark: $V1 < V2 < V3 < V4 < V5 < V6$, $F1 < F2 < F3 < F4 < F5 < F6$.

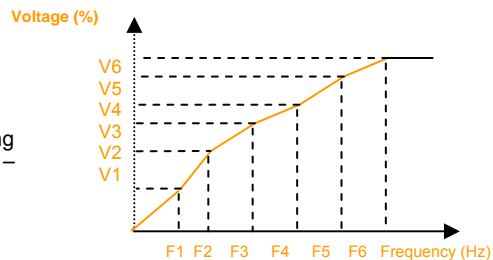

If **F137=3**, the slip compensation works in automatic – correct setting for all motor parameter is necessary to guarantee correct operation – AUTOTUNING may be used to find motor parameters, like inductance and stator resistance (see parameter group 8).



WARNING!! High voltage BOOST on low speed may result in inverter over-current trip and/or motor overheating

8) Parameter group 100: Basic parameters

F140 BOOST-kneefrequency (Hz)	Range: 0 – 5 Hz	Default setting: 1 Hz
F141 BOOST intensity (%)	Range: 0 – 25%	Default setting: 4 %

BOOST function allow additional voltage increase on low speed – see graphic (for F137=0 or F137=1).

F152 Maximum motor voltage (at knee frequency – modulation level)	Range: 10 – 100 %	Default setting: 100 %
--	-------------------	------------------------

This function is used to limit the maximum motor voltage – the percentage value refers to the corresponding input voltage (on 400 V power supply: 100%= 400 motor voltage)

	Range:	Default setting:
F153 PWM Frequency	0.2 - 7.5 kW: 800 Hz – 10.000 Hz	0,2...7,5 kW: 4kHz
	11 – 15 kW: 800 Hz – 10.000 Hz	11...15 kW: 3kHz
	18.5 kW – 45 kW: 800 Hz – 6.000 Hz	18,5...45 kW: 4kHz
	>55kW: 800 Hz – 4.000 Hz	<55 kW: 2kHz

F154 Power supply voltage compensation	Selection: 0: deactivated 1: activated 2: deactivated during deceleration ramp	Default setting: 0
---	--	--------------------

This function keeps the motor-voltage stable and independent from power supply voltage fluctuation. It may stretch the deceleration phase, therefore it can be deactivated during deceleration only (F154=2)

F155 Internal value for secondary speed reference	Range: 0...F111	Default setting: 0
F156 Polarity secondary speed ref. (direction)	Range: 0 (FWD) oder 1(REV)	Default setting: 0
F157 Secondary speed ref. readout		Read-only
F158 Secondary speed polarity readout		Read-only

Internal digital reference for secondary speed reference - analogue to F113

F159 „RANDOM“ PWM modulation	Selection: 0: constant PWM frequency 1: „RANDOM“ modulated PWM	Default setting: 1
-------------------------------------	---	--------------------

If F159=0: Inverter works with constant PWM frequency (as set in F153) - 159=1: PWM frequency is "random" over-modulated .

F160 Factory default reset	Selection: 0: Normal operation 1: Start factory default reset process	Default setting: 0
-----------------------------------	--	--------------------

Factory default reset procedure:

Select parameter **F160**, press **SET**, original parameter F160 value is 0, press **UP** key to set F160 to **1** press **SET** again
After a few seconds all factory default parameters are restored.

The value in F160 returns to 0, after the restore process is completed.

ATTENTION:

The factory reset process will not have effect on following parameters:

F400 F402 F406 F408 F412 F414 F732 F742 F745 F901

9) Parameter group 200: Inverter control

START / STOP / running direction:

F200 START command source	Selection: 0: Keypad only 1: Terminal input only 2: Keypad + terminal input 3: Serial link (MODBUS) 4: Keypad + terminal + serial link	Default setting: 4
F201 STOP command source	Selection: 0: Keypad only 1: Terminal input only 2: Keypad + terminal input 3: Serial link (MODBUS) 4: Keypad + terminal + serial link	Default setting: 4

- **F200** and **F201** are used to set the mode for inverter starting and stopping – via keypad key, digital input on terminals, MODBUS commands, or a combination of all three. All signals are dynamic, input pulses, are sufficient, to start/stop the inverter. **This parameters are valid only, if F208=0 (default), if F208>0, this setting will be ignored**



F202 Rotation direction preset	Selection: 0: forward 1: reverse 2: depending on terminal signals	Default setting: 0
---------------------------------------	--	---------------------------

If no other rotation direction signal (logic) present, the rotation depends on this parameter – e.g. in case of keypad control. Otherwise the direction depends on logical function of more direction signals

If (**F500=2**) – automatic frequency cycling – this parameter is ignored

Selection of speed reference sources:

F203 Primary speed reference source "X"	Selection: 0: Internal reference (F113) with automatic memory 1: Analogue input AI1 2: Analogue input AI2 3: Pulse input OP1 4: Fix-frequencies, terminal control (digital inputs) 5: same as 1, (F113) but no memory 6: Potentiometer in keypad (AI3) 7: reserved 8: reserved 9: PID controller output 10: MODBUS data	Default setting: 0
--	---	---------------------------

F203=0: Inverter accelerates after the first START command to the frequency value F113, using   keys, or proper configured digital terminal inputs, the user can vary the frequency, after a STOP command, the last frequency value will be automatically memorized. To activate the memorizing function in case of power-down too, it needs to set **F220=1**.

F203=1 - F203=2: this is the setting for speed reference through analogue channels AI1-AI2. Analogue channels may be configured for 0..10V, -10V...+10V, or 0(4)..20mA (on 500 Ohm). Configuration via DIP Switches on control board (see chapter: 5 *Hardware und hardware configuration of I/O channels*). Default: **AI1** = 0...10V, **AI2** = 0...20 mA. To realize 4...20mA, an offset can be programmed: **F406=2V**.

F203=3: Impulse train as speed reference. Max. 50 kHz, impulse input: **OP1**.

F203=4: Up to 16 fix programmed frequencies, selectable via programmable digital inputs OP1...OP8

F203=5: Same function as F203=0: Internal reference (**F113**), but no memory after STOP or power-down

F203=6: The keypad potentiometer works as speed reference signal (only for keypads with integrated potentiometer)

F203=9: PID controller output works as speed reference origin (for PID controller applications)

F203=10: Speed reference through serial link (MODBUS)

9) Parameter group 200: Inverter control

<p>F204 Secondary speed-reference source "Y"</p>	<p>Selection: 0: Internal reference (F155) – with memory 1: Analogue input AI1 2: Analogue input AI2 3: Pulse input OP1 4: Fix-frequencies, terminal control (digital inputs) 5: same as 1, (F155) but no memory 6: PID controller output 7: Potentiometer on keypad (AI3)</p>	<p>Default setting: 0</p>
---	---	----------------------------------

Secondary speed channel has the same function, as primary channel, if selected as the only reference. Setting parameter **F207**, both channels, primary and secondary can be concatenated each other.

If **F204=0**, the value in **F155** works as initial speed reference, if secondary channel is used alone, in this case the value in **F156** is ignored

If **F207=1** or **F207=3**: value in **F155** and **F156** are valid for the secondary speed reference source

F205 and **F206** determine the range of the secondary speed channel, if analogue channel AI1 or AI2 are used for sec. speed ref. input (F205=1 or 2)

If the potentiometer on the keypad panel is selected (F205=7), primary speed reference source is limited on fix-frequencies or MODBUS setting

It is not allowed to configure primary and secondary speed reference source through the same channel

<p>F205 Reference point for the range setting of the secondary speed reference channel, using AI1 or AI2</p>	<p>Selection: 0: referred on F-max 1: referred on the primary speed channel "X"</p>	<p>Default setting: 0</p>
<p>F206 Range for secondary speed ref. „Y“ (%)</p>	<p>Range: 0....100 %</p>	<p>Default setting: 100</p>

In case of combined speed control and secondary speed ref. input via **AI1** or **AI2**, parameter **F205** and **F206** determine the relation to the primary reference

Combined speed control – between primary and secondary speed reference

<p>F207 Output frequency as combination between primary ("X") and secondary ("Y") speed reference signal</p>	<p>Selection: 0: X, only primary reference is used 1: X+Y Sum of primary and secondary reference 2: X or Y (terminal input selection) 3: X or X+Y (terminal input selection) 4: X (Fix-frequencies) and Y (analogue) combined 5: X-Y Difference between primary and secondary value 6: X+Y(F206-50%) * (value defined in F205)</p>	<p>Default setting: 0</p>
---	---	----------------------------------

If **F207=1**: X+Y, the sum of both channels is used – it is not allowed to use PID controller output for speed reference signals .

If **F207=3**: X or (X+Y) determine the output frequency, selection via terminal digital input. – is not allowed to use PID controller output is not allowed for speed reference signal.

If **F207=4**: Fix-frequencies are the primary speed source, with priority to the analogue speed reference input for example (F203=4 und F204=1).

If **F207=5**: The difference between both speed reference channels determine the output frequency – PID controller output is not usable.

If **F207=6**: output frequency is set according to $X+(F206-50\%)*F205$ – PID controller output is not allowed

9) Parameter group 200: Inverter control

Kombinationsmöglichkeiten verschiedener Sollwertquellen

F204 F203	0 Internal digital set with memory t	1 External Analogue input AI1	2 Extern Analogue input AI2	4 Fix-frequency selection	5 PID controller	6 Keypad potentiom.
0 Internal digital set with memory	○	•	•	•	•	○
1 External Analogue input AI1	•	○	•	•	•	○
2 Extern Analogue input AI2	•	•	○	•	•	○
4 Fix-frequency selection	○	•	•	•	•	○
5 Internal digital set without memory	•	•	•	•	•	○
6 Keypad potentiom.	•	•	•	•	○	○
9 PID controller	•	•	•	•	•	•

•: Allowed ○: Not allowed

The automatic cycling frequency control algorithm can not work in any combination with others

Two / Three wire control for START – STOP - Rotation:

This control mode overwrites the setting in F200, F201, F202

<p>F208 Activation special Two / Three wire control</p>	<p>Selection: 0: Deactivated 1: Two-wire, Type 1 (static) 2: Two-wire, Type 2 (static) 3: Three wire, Typ1 (Impulse / pushbutton control – dynamic) 4: Three wire, Typ2 (Impulse / pushbutton control – dynamic) 5: Pulse / pushbutton control (dynamic)</p>	<p>Default setting: 0</p>
--	---	----------------------------------

F208=0: If Fixed-frequency control is required this mode must be deactivated!

If **F208>0:** functions **F200, F201** and **F202** are ignored.

“FWD”, “REV” and “X” are digital terminal input signals for two / three wire control mode. This logical signals are assigned to OP1.....OP6 (OP8) through parameters F316....F323

Assigning-code for OPxx: **FWD=15, REV=16, X=17** – see chapter: *Parameter group 300 – Digital I/O configuration*

F208=1: Two wire Type 1

K1=START forward (default on OP3)

K2=START reverse (default on OP4)

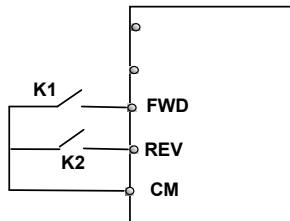

Truth table

K1	K2	
0	0	Stop
1	0	forward
0	1	reverse
1	1	Stop

F208=2: Two wire Type 2

K1=START (default on OP3)

K2=Rotating direction (default on OP4)

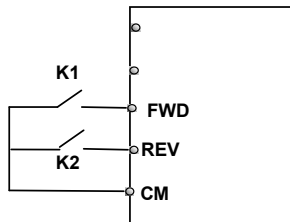

Truth table

K1	K2	
0	0	Stop
0	1	Stop
1	0	forward
1	1	reverse

F208=3: Three wire Typ 1

F208=4: Three wire Typ 2

Pulse/pushbutton control:

FWD(SB2)=START-impulse forward
FWD=NO

REV(SB1)=START-impulse reverse
REW=NO

X(SB3)=cancel impulse (STOP)
X=NC

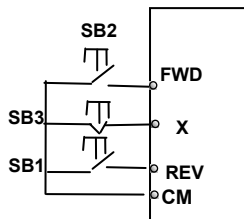

Pulse/pushbutton control:

FWD(SB1)=START-impulse
FWD=NO

X(SB2)=cancel-impulse (STOP)
X=NC

K1=Direction

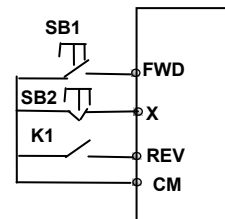

F208=5: Three wire Typ 3

Pulse/pushbutton control:

FWD (SB1) Impulse: START-forward / STOP
 Toggle function
FWD=NO

REV (SB2) Impulse: START-reverse / STOP
 Toggle function
REV=NO

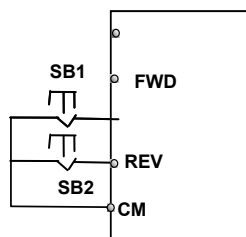

9) Parameter group 200: Inverter control

F209 "STOP" mode selection	Selection: 0: STOP controlled by deceleration ramp 1: Free-stop (uncontrolled)	Default setting: 0
-----------------------------------	---	---------------------------

If **F208=1**: STOP command disables the final stage, motor stops uncontrolled by inertia

F210 Frequency resolution with Motorpotentiometer control via keypad/terminals	Range: 0.01 - 2.00 Hz	Default setting: 0.01 Hz
---	------------------------------	---------------------------------

F211 Variation speed in Motorpotentiometer control mode via keypad/terminals	Range: 0.01 - 100.0 Hz/sec.	Default setting: 5.00 Hz/sec
---	------------------------------------	-------------------------------------

If **F203=0/5**: Inverter starts with initial frequency **F113** (memory with **F203=0**) – **F220=1**, to memorize with power-down too

F212 Status memory with (208=3)	Selection: 0: deactivated 1: activated	Default setting: 0
--	---	---------------------------

If activated, after power down or reset, the inverter will restart with the same status, as before (the previous start impulse forward/reverse was memorized)

F213 Autostart after power-down	Selection: 0: deactivated 1: activated	Default setting: 0
F214 Inverter-Error AUTO-RESET	Selection: 0: deactivated 1: activated	Default setting: 0
F215 Power-on Autostart delay (sec.)	Bereich: 0.1...3000.0 sec.	Default setting: 60.0

F213=1 will force the inverter to restart automatically in case of power off. On power-on, the inverter will restart with the same conditions, as before (frequency/direction). **F215** defines the delay time for power-on autostart. Power-on autostart works only with **F208=0** (dynamic start command)

F214=1 will cause an automatic reset in case of inverter error. **F217** is the delay time for error-reset, while **F215** works as delay time for restart after error-reset. Autostart is performed only if error occurs during START condition (motor running), in case of STOP condition, only error-reset will be done. In case of deactivated automatic error-reset, manual reset (keypad/terminal signal) must be done

F216 Number of error-reset tentative	Selection: 0 - 5	Default setting: 0
F217 Delay time for error-reset	Range: 0.0 - 10.0 sec.	Default setting: 3.0 sec.

F219 EEprom write protection under MODBUS control	Selection: 0: deactivated 1: activated	Default setting: 1
--	---	---------------------------

Please note that **F219**, the EE-prom write protection it is activated by default (to prevent EE-prom from getting destroyed due to repetitive write operations). With this configuration all data sent by MODBUS are stored in the RAM only and get lost after power-down.

If inverter works with continuously varying parameter values, like speed reference, it is recommended, to work in the RAM only.

F220 Memory function for speed and rotation direction in case of power-down	Selection: 0: deactivated 1: activated	Default setting: 0
--	---	---------------------------

Valid in case of internal speed reference (**F113**), (**F155 – F156**)

F277 Acceleration time 3 (sec.)	Range: 0,1 – 3000sec.	Default setting: depending on inverter size
F278 Deceleration time 3 (sec.)		
F279 Acceleration time 4 (sec.)		
F280 Deceleration time 4 (sec.)		

Alternative ramps, selectable via terminal commands, in the same way as Accel./Decel time 1/2

10) Parameter group 300: Digital I/O configuration

Following digital I/O channels are available on E800 inverters:

I/O	Inverter size E1-E6 (up to 22 kW)	Inverter size E7-E9 (> 22 kW)
Digital inputs	5 (DI1...DI5)	8 (DI1...DI8)
Digital outputs	1 (DO 1) Open Collector 100 mA / 24 V	2 (DO1, DO2) Open Collector 100 mA / 24 V
Relay output	1 switch-over 2 A 230V	1 switch-over 5 A 230V

Hardware-configuration: to perform as described in chapter 5) *Control hardware-configuration of I/O channels*

Parameters **F300-F302** (for outputs) and **F316-F323** (for inputs) allow assignation of various functions to digital I/O channels

Function mapping for digital output channels:

F300 Relais output	Mapping for functions : 0.....42 See table below	Default setting 1 (error)
F301 DO1 Digital output 1		Default setting 14 (Inv. enable)
F302 DO2 Digital output 2		Default setting 5 (START)

Value	Function	Description
0	No function	No function assigned
1	Inverter error	The output is active in case of inverter error
2	Freq. threshold 1	If output frequency reaches the threshold, the output will be activated, threshold, including hysteresis programmable with parameters F307, F308, F309
3	Freq. threshold 2	
4	Inverter disable	Free-STOP command on terminals (system in inertia)
5	Inverter START-1	Inverter in START mode, motor runs, (frequency > 0 Hz)
6	DC Brake	Inverter in DC-Brake mode
7	Rampset 2 selection	Second Accel/Decel. ramp set has been selected
8	Reserve	
9	Reserve	
10	Inverter overload WARNING	In case of inverter overload, a warning is set, after half the switch off delaytime has passed. Load reduction to cancel, otherwise overload trip (OL1)
11	Motor overload WARNING	Early warning in case of motor overload – similar function as (10) – if no load reduction, overload trip with (OL2) in the display
12	Temp. Ramp stop	Acce./Decel ramp temporarily stopped (Limiting function activated F607...F610)
13	Inverter OK	Inverter is powered on and ready without any error
14	Inverter START - 2	Inverter enabled, similar to 5 but also active with F=0 (final stage enabled)
15	Target freq. reached	Acce./Decel. ramp finished (final freq. reached) (hysteresis to set in F312)
16	WARNING overtemp.	At 80% of the temperature switch-off limit, inverter may trip with (OH) if no cooling
17	Current limit	Inverter has reached the current limit, programmable in F310 and F311
18	Analogue signal interruption	Analogue input signal below the programmable threshold, (see F741/742 and F400/406)
19	Reserve	
20	Prealarm lack of water	Motor-current fallen below the programmed value (see F754, F755).
21	Modbus-controlled	Output controlled by MODBUS: Set code: 2005H = 1 , Reset code: 2005H=0
22	Modbus-controlled	Output controlled by MODBUS: Set code: 2006H = 1 , Reset code: 2006H=0
23	Modbus-controlled	Output controlled by MODBUS: Set code: 2007H = 1 , Reset code: 2007H=0
24	Watchdog	Watchdog signal missing

Activation and configuration of the "S" shaped ramp

F304 Initial progression	Range: 2.0...50%	Default setting 30%
F305 Final progression		
F306 "S" shaped ramp activation	Selection: 0=Linear ramp 1="S" ramp	Default setting 0

Frequency threshold setting

F307 Frequency threshold 1 (Hz)	Range: F112 - F111 (Hz)	Default setting 10Hz
F308 Frequency threshold 2 (Hz)		Default setting 50Hz
F309 Hysteresis	Range: 0...100%	Default setting 50 %

This are frequency thresholds for signalling through programmable digital outputs - function assignation: 2 / 3.
Hysteresis to subtract from threshold value

Current threshold

F310 Stromschwelle (A)	Range: 0...1000 A	Default setting Nennstrom
F311 Hysterese Stromschwelle	Range: 0...100%	Default setting 10%

Current threshold, signalled through programmable digital outputs - function assignation: 17.
Hysteresis to subtract from threshold value

F312 Hysteresis to target frequency (Hz)	Range: 0.00...5.00 Hz	Default setting 0.00
---	-----------------------	----------------------

-Valid for the "end of ramp" message through digital outputs – output function assignation: 15
- Hysteresis to subtract from threshold value

Function mapping for digital input channels DI1 – DI8

F316 Function assignment to DI1	Function mapping: 0...53	Default setting 11 (JOG-forward)
F317 Function assignment to DI2		Default setting 9 (EMERGENCY-STOP EXT.)
F318 Function assignment to DI3		Default setting 15 (TERMINAL "FORWARD")
F319 Function assignment to DI4		Default setting 16 (TERMINAL "REVERSE")
F320 Function assignment to DI5		Default setting 7 (RESET)
F321 Function assignment to DI6		Default setting 8 (STOP-DISABLE)
F322 Function assignment to DI7		Default setting 1 (START)
F323 Function assignment to DI8		Default setting 2 (STOP)

Attention: One function can be assigned to one single digital input only (no multiple inputs) If a function is already assigned to a certain input (factory set), this assignment must be deleted (set assignment to 0), before assigning to another input.

Table of digital input functions

VALUE	Function	Description
0	No function	No function assigned, for unused inputs
1	START function	The input starts the drive system – same as "RUN" on keypad
2	STOP function	Input stops the system – same as "STOP" on keypad
3	Fix-frequency K1	15-Fix-programmed frequencies are selectable (see table below 300-1)
4	Fix-frequency K2	
5	Fix-frequency K3	
6	Fix-frequency K4	
7	RESET	General reset, error reset – same as "STOP/RESET" on keypad
8	STOP-DISABLE	"Free STOP" system stops with inertia (logical inversion: F324)
9	EMERGENCY STOP	Ext. Emerg. STOP signal, ESP on display (signal logic: F325)
10	RAMPSTOP	Inverter holds the actual frequency, independent from other signals (except STOP signal) – ramps are stopped
11	JOG forward	JOG control, see F124, F125 and F126 for parametrizing
12	JOG reverse	
13	Motorpotentiometer +	Motorpotentiometer-function, to increase/decrease frequency, (with internal speed reference F203=0 / 5, control parameter: F113, F210, F211).
14	Motorpotentiometer -	
15	Terminal "FWD"	Assignment of terminal function "FWD", "REV", and "X" (see two/three wire control – parameter F208)
16	Terminal "REV"	
17	Terminal "X"	
18	BIT1 Ramp set selection	Selection of Acce./Decel. ramp set (BIT1) – (see table 300-2)
19	Reserved	--
20	Reserved	
21	Reference source	Selection of different speed reference sources - combinations (see F207)
22-31	Reserved	
32	FIRE pressure	To select "Fire Mode" pressure setpoint (parameter FA58).
33	FIRE MODE	Activation of the "FIRE MODE" (FA59)
34	BIT2 Ramp set selection	Selection of Accel. / Decel. ramp set (BIT2) – (see table 300-2)
37	NTC / NO	Motor heath monitoring via NTC / NO contact (KLIXON)
38	PTC / NC	Motor heath monitoring via PTC / NC contact (KLIXON)
53	Watchdog	Watchdog control-pulse input

Fixed-frequencies selection – table 300-1

K4 6	K3 5	K2 4	K1 3	Frequency	Programming parameter
0	0	0	0		
0	0	0	1	Fixed-frequency 1	F504/F519/F534/F549/F557/F565
0	0	1	0	Fixed-frequency 2	F505/F520/F535/F550/F558/F566
0	0	1	1	Fixed-frequency 3	F506/F521/F536/F551/F559/F567
0	1	0	0	Fixed-frequency 4	F507/F522/F537/F552/F560/F568
0	1	0	1	Fixed-frequency 5	F508/F523/F538/F553/F561/F569
0	1	1	0	Fixed-frequency 6	F509/F524/F539/F554/F562/F570
0	1	1	1	Fixed-frequency 7	F510/F525/F540/F555/F563/F571
1	0	0	0	Fixed-frequency 8	F511/F526/F541/F556/F564/F572
1	0	0	1	Fixed-frequency 9	F512/F527/F542/F573
1	0	1	0	Fixed-frequency 10	F513/F528/F543/F574
1	0	1	1	Fixed-frequency 11	F514/F529/F544/F575
1	1	0	0	Fixed-frequency 12	F515/F530/F545/F576
1	1	0	1	Fixed-frequency 13	F516/F531/F546/F577
1	1	1	0	Fixed-frequency 14	F517/F532/F547/F578
1	1	1	1	Fixed-frequency 15	F518/F533/F548/F579

Please note: If F500=1, binary selection K1...K4 – for direct selection via K1...K4, use fixed-frequency 1, 2, 4 and 8
If (F500=0) K1...K3 may be used for direct selection of 3 fixed frequencies

Accel./Decel. ramp selection - table 300-2

BIT1 Function assignation 18	BIT2 Function assignation 34	Accel./Decel. Ramp-set	Programming parameter
1	0	Ramp set 1	F114 / F115
0	0	Ramp set 2	F116 / F117
1	1	Ramp set 3	F277 / F278
0	1	Ramp set 4	F279 / F280

F324 "STOP - DISABLE" logic selection (8)	Selection: 0=LOW active (NPN) 1=HIGH active (PNP)	Default setting 0
F325 "EMERGENCY -STOP EXTERN" logic (9)		Default setting 0
F326 Watchdog delay time	Range: 0,1...30.000 sec.	Default setting 10,0 sec
F327 Watchdog STOP mode	Selection: 0=free STOP 1=ramp STOP	Default setting 0
F328 Digital input filter factor	Range: 1...100	Default setting 10

IF 326=0: The watchdog function is deactivated. Watchdog function can only work, if one digital input is mapped as watchdog pulse input (53)

11) Parameter group 400: Analogue I/O channel configuration

Two different control boards are used in E800 inverters, depending on inverter framesize:

Inverter power-range up to 22 kW – SIZE E1-E6
 Inverter power-range from 30 - 90 kW – SIZE C3-C6

Both control boards offers independent analogue input/output channels. Each of them can be adapted to various input/output signals – all configuration must be done by software/hardware setting

Details and instruction for hardware setting: see chapter 5) *Control hardware and IO/ channel configuration*

Following instruction describes, how to set software parameters

Configuration of analogue speed reference channels **AI1, AI2, AI3** (A3 = potentiometer on keypad):

F400 Range definition AI1 – lower limit (V)	Range 0.00V...F402	Default setting: 0.00V
F401 Assignation lower limit AI1	Range: 0...F403	Default setting: 1.00
F402 Range definition AI1 – upper limit (V)	Range: F400...10.00V	Default setting: 10.00V
F403 Assignation upper limit AI1	Range: (1.00, F401)...2.00	Default setting: 2.00
F404 Gain factor AI1	Range: 0.0...10.0	Default setting: 1.0
F405 AI1 Filter factor AI1	Range: 0.1...10.0	Default setting: 0.10

The speed range is defined by upper and lower limits, the area in between corresponds to 100% (example: F400=2, F402=8, 2...8V correspond to 0...100%)

Parameter F401 and F403 are used to move the range limits (in %). Rules: 0 = -100%, 1 = 0%, 2 = +100%. (example: F401=0, F403=2 then 100% signal (the range between upper and lower limit) correspond to -100%...+100% reference). In this case 0...10V input signal corresponds to - 50 Hz...0Hz...+50 Hz).

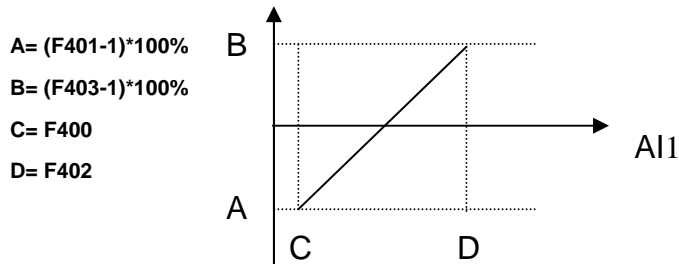

Configuration examples:

Speed reference channel selected: **AI1 - F203=1**,
F-max:F111=50 Hz, F-min:F112=0Hz
 All other: default set

Speed reference	Output frequency	F400	F401	F402	F403	F404	Hardware setting
0..10V	0Hz...+50 Hz	0.00V	1.00	10.00V	2.00	1.0	0...10V
0...10V	-50Hz...0Hz...+50Hz	0.00V	0.00	10.00V	2.00	1.0	0...10V
0...10V	-50Hz...0Hz	0.00V	0.00	10.00V	1.00	1.0	0...10V
0...10V	20Hz...50 Hz	0.00V	1.40	10.00V	2.00	1.0	0...10V
0...20mA	0Hz...50Hz	0.00V	1.00	10.00V	2.00	1.0	0...20mA
4...20mA	0Hz...50Hz	2.00V	1.00	10.00V	2.00	1.0	0...20mA

11) Parameter group 400: Analogue I/O channel configuration

Same configuration for AI2 and AI3 (= keypad potentiometer)

F406 Range definition AI2 – lower limit (V)	Range 0.00V...F402	Default setting: 0.00V
F407 Assigment lower limit AI2	Range: 0...F403	Default setting: 1.00
F408 Range definition AI2 – upper limit (V)	Range: F400...10.00V	Default setting: 10.00V
F409 Assigment upper limit AI2	Range: (1.00, F401)...2.00	Default setting: 2.00
F410 Gainfactor AI2 (%)	Range: 0.0...10.0	Default setting: 1.0
F411 Filter factor AI2	Range: 0.1...10.0	Default setting: 0.10

F412 Range definition AI3 – lower limit (V)	Range 0.00V...F402	Default setting: 0.00V
F413 Assigment lower limit AI3	Range: 0...F403	Default setting: 1.00
F414 Range definition AI3 – upper limit (V)	Range: F400...10.00V	Default setting: 10.00V
F415 Assigment upper limit AI3	Range: (1.00, F401)...2.00	Default setting: 2.00
F416 Gainfactor AI3 (%)	Range: 0.0...10.0	Default setting: 1.0
F417 Filter factor AI3	Range: 0.1...10.0	Default setting: 0.10

F418 0 Hz Dead band 0 Hz AI1	Range: +/- 0...0.50V	Default setting: 0.00
F419 0 Hz Dead band 0 Hz AI2	Range: +/- 0...0.50V	Default setting: 0.00
F420 0 Hz Dead band 0 Hz AI3	Range: +/- 0...0.50V	Default setting: 0.00

0 Hz dead band: If frequency crosses 0Hz range (depending on signal range setting), 0 Hz output frequency will result, within the 0 Hz dead band.

Panel / potentiometer selection (inverter with remote keypad / keypad potentiometer option)

F421 Operating panel	Selection: 0=Integrated panel, 1=Remote panel	Default setting: 0
F422 Potentiometer	Selection: 0=Integrated panel potentiometer 1=Remote panel potentiometer	Default setting: 0

F421=1 Remote operation panel selected, the integrated panel is deactivated, including potentiometer (regardless setting on F422).

This configuration can not be reset to factory default (via F160)

F437 Analog filter hysteresis	Range: 1...100	Default setting: 10
-------------------------------	----------------	---------------------

Higher hysteresis value will result in a more stable system, but with longer reaction time on changing speed reference signal

Non-linear characteristic for analogue channels

A non-linear characteristic can be assigned to analogue input channels **AI1** and **AI2**. Programming is done in sense of the table below

<i>F460</i> Characteristic AI1	Selection: 0=linear 1=non-linear	Default setting: 0
<i>F461</i> Characteristic AI2	Selection: 0=linear 1=non-linear	Default setting: 0
<i>F462</i> input level 1 for AI1	Range: F400 - F464	Default setting: 2.00V
<i>F463</i> Assignment input level 1 (%)	Range: F401 - F465	Default setting: 1.20
<i>F464</i> input level 2 for AI1	Range: F462 - F466	Default setting: 5.00V
<i>F465</i> Assignment input level 2 (%)	Range: F463 - F467	Default setting: 1.50
<i>F466</i> input level 3 for AI1	Range: F464 - F402	Default setting: 8.00V
<i>F467</i> Assignment input level 3 (%)	Range: F465 - F403	Default setting: 1.80
<i>F468</i> input level 1 for AI2	Range: F406 - F470	Default setting: 2.00V
<i>F469</i> Assignment input level 1 (%)	Range: F407 - F471	Default setting: 1.20
<i>F470</i> input level 2 for AI2	Range: F468 - F472	Default setting: 5.00V
<i>F471</i> Assignment input level 2 (%)	Range: F469 - F473	Default setting: 1.50
<i>F472</i> input level 3 for AI2	Range: F470 - F412	Default setting: 8.00V
<i>F473</i> Assignment input level 3 (%)	Range: F471 - F413	Default setting: 1.80

Assignment of intermediate points, in the same way as for endpoints
(0= -100%, 1=0%, 2=+100%)

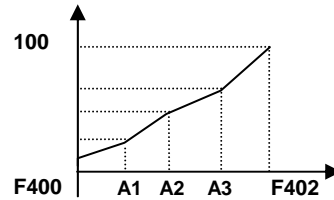

11) Parameter group 400: Analogue I/O channel configuration

Analogue output configuration **AO1, AO2**

F423 Signal type configuration output AO1 current/voltage signal	Selection: 0=0...5V 1=0...10V, 0...20mA * 2=4...20mA *	Default setting: 1
F424 Inverter output frequency assigned to minimum output signal on AO1	Range: 0.0...F425	Default setting: 0.05 Hz
F425 Inverter output frequency assigned to maximum output signal on AO1	Range: F424...F111	Default setting: 50.00 Hz
F426 Gain factor AO1	Range: 0...120%	Default setting: 100

*) The DIP-SWITCH U/I must be set, to get current signal on AO 1 output – see chapter 5) Control hardware and IO/channel configuration

F427 Signal type configuration output AO2 current signal only	Selection: 0=0...20 mA 1=4...20mA	Default setting: 0
F428 Inverter output frequency assigned to minimum output signal on AO2	Range: 0.0...F429	Default setting: 0.05 Hz
F429 Inverter output frequency assigned to maximum output signal on AO2	Range: F428...F111	Default setting: 50.00 Hz
F430 Gain factor AO2	Range: 0...120%	Default setting: 100

(AO2 for inverter size C3-C6 only)

F431 Assignment of operating parameters to AO1	Selection: 0=Motor frequency 1=Motor-current normalized on 2xl-n) 2=Motor-voltage (normalized on 230/400V) 3=AI1 4=AI2 5=Reserved 6=Reserved 7=Set via MODBUS 8=Target frequency 9=Calculated speed	Default setting: 0
F432 Assignment of operating parameters to AO2		Default setting: 1

F433 Multiplier for motor voltage meter	Range: 0.01...5* rated value	Default setting: 2.0
F434 Multiplier for motor current meter		Default setting: 2.0
F437 Filter factor analogue output	Range: 1...100	Default setting: 10

Assignment to motor current: The range 0...100% corresponds to 0....2x inverter rated current

Assignment to motor voltage: The range 0...100% corresponds to 0.....motor rated voltage (230 / 400V)

12) Parameter group 500: Fixed-frequency, automatic cycling frequencies

Up to 15 fixed-frequencies are selectable on E800 inverters, including individual ramp and direction setting. Automatic cycling sequence for up to 8 fixed-frequencies can be set, including ramp, direction, run- and pausing time.

Set parameter **F203=4 (F204=4)**, to select fixed frequency mode:

F500 Fixed-frequency mode selection	Selection: 0: 3 Fixed frequencies are available 1: 15 Fixed frequencies available, binary coded (K1, K2, K3, K4 - terminal) 2: Up to 8 Fixed frequencies – auto-cycling mode	Default: 1
--	---	------------

F203	F500	Fixed frequency mode	Description
4	0	3 Fixed frequencies direct selection	To combine with analogue control, fixed-frequencies have priority
4	1	15 Fixed frequencies binary selection	To combine with analogue control, fixed-frequencies have priority
4	2	Up to 8 auto-cycling fixed frequencies	Independent mode, no manual frequency control is possible during cycle, except STOP command – F501, F502, F503 are the auto-cycling parameters

Auto-cycling parameter:

F501 Number of different frequencies for auto-cycling function	Selection: 2...8	Default setting: 7
F502 Number of automatic cycles	Range: 0...9999 0 = Endless cycling	Default setting: 0
F503 Status after cycle completed	Selection: 0: Stop 1: Keep last valid frequency	Default setting: 0

Programming of the individual fixed-frequencies:

	Acceleration ramp fixed-frequencies 1 - 15 (0,1...3000sec.) (default)	Deceleration ramp fixed-frequencies 1 - 15 (0,1...3000sec.) (default)	Rotation direction fixed-frequencies 1 - 15 – (0=FWD, 1=REV)	Auto-cycle - duration for fixed-frequencies 1 - 8 (0,1...3000sec.) (1sec.)	Auto-cycle – pausing time for fixed-frequencies 1 - 8 (0,1...3000sec.) (0sec.)	Default setting: Accel./Decel. time, depending on inverter model 0.2 - 4.0KW: 5.0 sec. 5.5 - 30KW: 30.0 sec. >30kW: 60 sec.
F504 Fixed-frequency 1 (Hz)	F519	F534	F549	F557	F565	Range for F504 – F518: F112F 111 Default: 5.00Hz Default: 10.00Hz Default: 15.00Hz Default: 20.00Hz Default: 25.00Hz Default: 30.00Hz Default: 35.00Hz Default: 40.00Hz Default: 5.00Hz Default: 10.00Hz Default: 15.00Hz Default: 20.00Hz Default: 25.00Hz Default: 30.00Hz Default: 35.00Hz
F505 Fixed-frequency 2 (Hz)	F520	F535	F550	F558	F566	
F506 Fixed-frequency 3 (Hz)	F521	F536	F551	F559	F567	
F507 Fixed-frequency 4 (Hz)	F522	F537	F552	F560	F568	
F508 Fixed-frequency 5 (Hz)	F523	F538	F553	F561	F569	
F509 Fixed-frequency 6 (Hz)	F524	F539	F554	F562	F570	
F510 Fixed-frequency 7 (Hz)	F525	F549	F555	F563	F571	
F511 Fixed-frequency 8 (Hz)	F526	F541	F556	F564	F572	
F512 Fixed-frequency 9 (Hz)	F527	F542	F573			
F513 Fixed-frequency 10	F528	F543	F574			
F514 Fixed-frequency 11	F529	F544	F575			
F515 Fixed-frequency 12	F530	F545	F576			
F516 Fixed-frequency 13	F532	F546	F577			
F517 Fixed-frequency 14	F532	F547	F578			
F518 Fixed-frequency 15	F533	F548	F579			

13) Parameter group 600: DC-Brake control / Aux. functions

DC-Brake function parameters:

F600 DC-Brake function activation	Selection: 0: DC-Brake deactivated 1: DC injection before START 2: DC injection after STOP 3: Before START and after STOP	Default setting 0
F601 Frequency threshold for DC-injection	Range: 0.2...5.0 Hz	Default setting 1.00 Hz
F602 Intensity DC-Brake START	Range: 0...100%	Default setting 10
F603 Intensity DC-Brake STOP		
F604 DC-Brake duration START	Range: 0.0 - 10.0 sec.	Default setting 0.5 sec.
F605 DC-Brake duration STOP		
F606 DC- Brake mode	Selection: 0=Voltage controlled 1=Current controlled 2=Auto-Voltage controlled	Default setting 0

Parameter for DC-Brake control:



Attention!! Improperly programmed DC-Brake function may result in inverter overcurrent trip and/or motor overheating

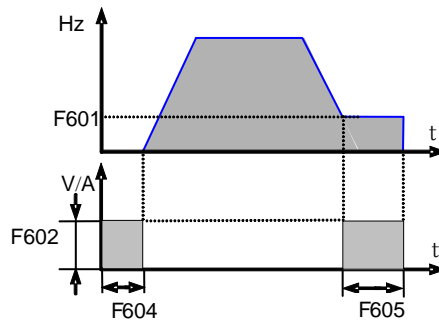

DC-Brake active optional signaled through digital output – function assignation: 6

Current- Voltage limiting functions

Limiting functions for current and voltage are available in standard E800 inverters

Current limiting function: This function allow to program a motor current threshold. If motor current reaches the threshold (F608) during acceleration, the acceleration ramp will hold on, until current drops below the limit. If current exceed the limit at target frequency (ramp completed), the frequency will be reduced, if necessary, down to the minimum frequency. Current limiting function is always deactivated during deceleration ramp.

Voltage limiting function: To limit the DC-link voltage increase, due to energy regeneration during deceleration phase. If voltage reaches the limit (F609), the limiting function will stretch the deceleration ramp.

The limiting status of the inverter can be signaled through any programmable digital output. Function assignation code: 12

F607 Activation of both limiting functions	Selection: 0: activated 1: deactivated	Default setting: 0
F608 Current limit (% rated current)	Range: 60...200 %	Default setting: 160 %
F609 DC voltage limit (% rated voltage)	Range: 60...200 %	Default setting: 140 %
F610 Max. duration if limiting status (sec.)	Bereich: 0.1...3000.0 sec.	Default setting: 5.0 sec.

If limiting status of the inverter takes longer than the time, set in F610, the system will stop, and OL1 will appear on the display.

Brake Chopper control (internal brake chopper)

F611 Brake chopper activation Threshold (V)	Range: 200...1000 V DC	Default setting: 400V inverter: 770V DC 230V inverter: 380 V DC
F612 Max. duty-cycle chopper	Range: 0...100 %	Default setting: 80 %
F622 Brake chopper mode	Selection: 0=Fixed duty cycle 1=Automatic controlled duty-Cycle	Default setting: 0

"Catch on the fly" function: To get already spinning motor controlled

F613 Activation of the function	Selection: 0: Function deactivated 1: Always active 2: Active after POWER_ON	Default setting: 0
F614 Scan process starting from:	Selection: 0: Last memorized frequency 1: Max. frequency 2: Last frequency and direction 3: Max. frequency and last direction	Default setting: 0
F615 Scan speed	Range: 1...100	Default setting: 20
F619 Timeout - Scan process	Range: 0,0....3000.0 sec.	Default: 60.0 sec.
F627 Current limiting	Bereich: 50....200%	Default: 100 %

F619: Timeout Scan-process: If the scan process takes longer than the time, programmed in (F619), the system will stop, error displayed by FL on the keypad

DC-voltage control

F631 DC-voltage control setting	Selection: 0: Active 1: Deactivated	Default setting: 0
F632 Nominal voltage for DC-control	Range: 200....800 V	Default: 380V DC / 700V DC
F633 DC-control frequency adaption band (Hz)	Range: 0,01...10 Hz	Default: 5,00 Hz

IF F631=1: The inverter will try to keep DC-voltage constant for different regenerating load conditions (during deceleration ramp or in case of motor generator function). Reduction of braking torque, or frequency adaption

14) Parameter group 700: Error handling and protection functions

Errorcodes (on display)

CODE	Description	Reason	Remedy
O.C.	Over-current – hardware detected	Too short ramps, short circuit on output motor defect, system blocked, wrong motor parameter setting	Increase Accel/Decel ramp time Check cabling / motor Check mechanical system Reduce BOOST Check motor parameter setting
OC1	Over-current – software detected		
O.L1	Inverter overload	Overload	Reduce load Check for right dimensioning
O.L2	Motor overload	Overload	
O.E.	DC-link over-voltage	Input power over-voltage Too high inertia Deceleration ramp too short Improper PID controller parameter	Check for correct supply voltage Inverter rated voltage correct?? Use larger brake resistors Increase deceleration time
P.F1.	Phase-loss Input	One input-phase missing	Check power supply
PFO	Phase-unbalance output	Motor-phase / cabling interrupted	Check cabling / check motor
L.U.	Undervoltage	Voltage on DC_Link too low	Check power supply
O.H.	Inverter overheat	Environment temperature too high Poor cabinet heat-exchange Inverter / heatsink polluted PWM frequency too high Motor cable too long	Check for environment / working conditions Insert all parameters correctly Check for correct inverter mounting
AErr	Analogue signal interruption	The analogue signal value is below the lower limit, programmed in F4xx parameters	Inspect control cabling Insert correct parameters for analogue signal lower limit Measure reference signal source
nP	Pump control: Pressure beyond limits	Pressure beyond limits Inverter in SLEEP mode	Insert correct pump controller parameters – open water flow
CE	MODBUS time-out	MODBUS signal missing	Check MODBUS cabling / source – MODBUS parameter setting
FL	Time-out "Catch on the fly" function	Synchronizing time exceeded the value in F619	Optimize "Chatch" parameters
ERR1	Wrong password Parameter change not successful	No or wrong password input Parameter change not allowed	Insert correct password STOP inverter to allow parameter change (<i>for certain parameters only</i>)
ERR2	Autotuning error	Motor can not free rotate during dynamic testing cycle	Separate motor from drive system
ERR3	Overcurrent in STOP condition	Hardware failure	Visual inspection of internal cabling Contact BLU service-center
ERR4	Current sensor error	No current signal on control board	Visual check of internal cabling, contact BLU service-center
ERR5	PID ERROR	PID controller error, due to improper PID parameter	Set PID parameter correctly
ERR6	Watchdog Timeout	Timeout caused by missing watchdog signal	Check signal on dig. input - assign digital input to watchdog function

Error messages through any digital output:

Function assignation code **1**: **Inverter error** message

Function assignation code **13**: **Inverter OK** message

14) Parameter group 700: Error handling and protection functions

Programmable delay for STOP- DISABLE with STOP signal through terminal

F700 Delay selection	Selection: 0: immediate STOP/DISABLE 1: with delay	Default setting: 0
F701 Delay time setting (sec.)	Range: 0.0...60.0 sec.	Default setting: 0.0 sec.

Only for signal through terminal (digital input) (F201=1/2/4, F209=1)

Fan control mode

F702 Fan control mode setting	Selection: 0: temperature-controlled 1: ON with inverter on power 2: ON with inverter in START mode	Default setting: 2
--------------------------------------	---	--------------------

F702=0: Temperature controlled, fan switch on, after temperature reaches the threshold, set in **F703**.

F702=2: Fan is switched on as long, as inverter in START mode, after STOP command, fan-runtime is extended, until heatsink temperature falls below 40°C.

Single phase inverter, framesize **E1** do not have fan control mode selection, fan is always ON, when inverter on power supply

Inverter/Motor over-load protection

Free programmable threshold values for warning and inverter-error trip.

Digital outputs, to program for warning messages (function assignation **10 / 11**)

F704 Threshold for warning INVERTER OVERLOAD (%) 10	Range: 50 - 100%	Werk: 80 %
F705 Threshold for warning MOTOR OVERLOAD (%) 11	Range: 50 - 100%	Werk: 80 %
F706 Threshold for INVERTER overload trip (%)	Range: 120 - 190%	Werk: 150 %
F707 Threshold for motor overload trip (%)	Range: 20 - 100%	Werk: 100 %

% values refer to relative motor / inverter rated values

All warnings are delayed, depending on overload grade

Warning for motor overload depends on working frequency too

Following graphics, to show warning delay characteristic:

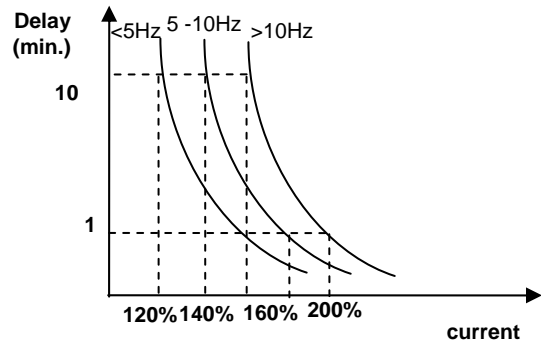
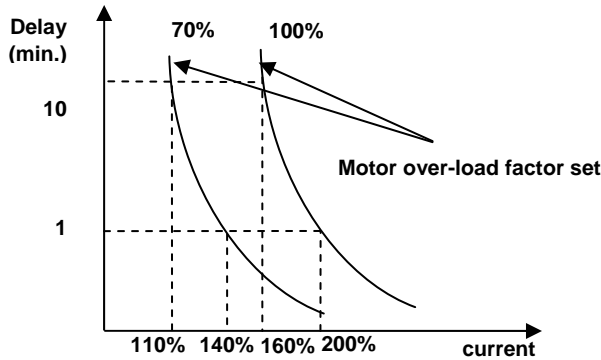

Fault history

Read only parameters, for inverter error codes:

F708 Last fault	Fault codes: 2: Overcurrent Hardware (OC) 3: Overvoltage (OE) 4: Phaseloss input (PF1) 5: Inverter overload (OL1) 6: Undervoltage (LU) 7: Inverter overtemperature (OH) 8: Motor overload (OL2) 11: External emergency STOP (ESP) 13: AUTOTUNING error (Err2) 16: Overcurrent software (OC1) 17: Motor phase unbalanced (PF0) 18: Analogue signal interruption AErr 23: PID improper parameters ERR5 45: MODBUS time-out CE 49: Watchdog time-out ERR6	F711 Frequency at last fault (Hz) F712 Current at last fault (A) F713 DC-Link voltage at last fault (V)
F709 Fault last but one		F714 Frequency at fault last but one (Hz) F715 Current at fault last but one (A) F716 DC-Link voltage at fault last but one (V)
F710 Fault last but two		F717 Fault last but two (Hz) F718 Current at fault last but two (A) F719 DC-Link voltage at fault last but one (V)

Error: event counter:

F720 Overcurrent	OC	
F721 Overvoltage	OE	
F722 Overtemperature	OH	
F723 Overload	OL1	

Protection functions – configuration

Activation of phase-loss, under-voltage and temperature monitoring

F724 Input phase-loss monitoring	Selection: 0: deactivated 1: activated	Default setting: 1
F725 Under-voltage monitoring	Selection: 0: deactivated 1: activated	Default setting: 1
F726 Over-temperature monitoring	Selection: 0: deactivated 1: activated	Default setting: 1
F727 Motorphase monitoring	Selection: 0: deactivated 1: activated	Default setting: 0

Delay for inverter error trip

F728 Delay phase-loss detection (sec.)	Range: 0.1 - 60.0 sec.	Default setting: 0.5 sec.
F729 Delay for under-voltage detection (sec.)	Range: 0.1 - 60.0 sec.	Default setting: 5.0 sec.
F730 Delay for over-temperature detection (sec.)	Range: 0.1 - 60.0 sec.	Default setting: 5.0 sec.
F732 Threshold for under-voltage detection (V) (DC-Link voltage)	Range: 0.1 – 450V	230V inverter: 215 V 400V inverter: 400 V

Overcurrent detection via software

F737 Software controlled overcurrent detection	Selection: 0: deactivated 1: activated	Default setting: 0
F738 Software current limit (rated current unit)	Range: 0.50 - 3.00	Default setting: 2.0
F739 SW over-current inverter-trip counter		

14) Parameter group 700: Error handling and protection functions

Analogue signal interruption detection (message via digital output – function code 18)

F741 Analogue signal interruption – fault handling mode	Selection 0: deactivated 1: STOP and AErr on display 2: STOP without any message on display 3: Inverter continue running with f-min 4: Reserved	Default setting: 0
F742 Threshold for detection (%)	Range: 1...100 %	Default setting: 50%

If **F400 / F406** set lower than 0.01V interruption detection is deactivated (a minimal value of 1V is recommended)
 Detection threshold is referred to lower limits for analogue input signals, set in parameters **F400 / F406**

Heatsink over-temperature warning (message via digital output – function code 16)

F745 Warning threshold (%)	Range: 0...100%	Default setting: 80
F747 Temperature depending carrier frequency adaption	Selection: 0: deactivated 1: activated	Default setting: 1

All referred to 95°C, the inverter trip temperature
 With temperature depending PWM frequency-adaption activated (**F747=1**), inverter will start to decrease PWM frequency gradually, at heatsink temperature of 86°C
 If PWM frequency is configured for "RANDOM" (**F159=1**), temperature depending PWM adaption is always deactivated

Idling detection (message via digital output – function code 20)

F754 Idling current threshold (%)	Range: 0...200 %	Default setting: 5%
F755 Delay time for idling detection (sec.)	Range: 0...60 sec.	Default setting: 0.5 sec.

15) Parameter group 800: Autotuning – Motor data programming

All motor data must be programmed exactly, as reported on motor nameplate.

Intelligent AUTOTUNING functions are available, to measure, and memorize unknown motor data.

F800 Automatic motor-data measurement (AUTOTUNING)	Selection: 0: AUTOTUNING deactivated 1: START dynamic AUTOTUNING 2: START static AUTOTUNING	Default setting: 0
F801 Motor-rated power (kW)	Range: 0.2...1000 kW	
F802 Motor-rated voltage (V)	Range: 1...440 V	
F803 Motor-rated current (A)	Range: 0.1...6500 A	
F804 Number of poles (p) (read only!!)	Range: 2...100 Pole	Default setting: 4 Pole
F805 Rated speed (rpm)	Range: 1...30000 U/min	
F810 Motor-rated frequency (Hz)	Range: 1.0...300.0 Hz	Default setting: 50.00Hz

Attention: The number of poles parameter is "READ ONLY" - it is automatically calculated using rated motor speed and rated motor frequency

F800=0: No AUTOTUNING, after parameter F801...F803, F805 and F810 are set, standard values are chosen for remaining parameters

F800=1: Dynamic AUTOTUNING – motor without load. After input of motor nameplate data in **F801...F805** and **F810**, the process can be started in the following way:

Set **F800=1**, press  key; The automatic process starts now, „**TEST**“ shown on display, after a few seconds, the motor will accelerate and decelerate, with ramps, programmed in F114 and F115. After completion of the cycle, all motor data will be stored, and **F800** will reset to 0

F800=2: Static AUTOTUNING, if there is no way to separate the motor from the load, static data measurement is available – the motor will not rotate during the cycle, and it is not allowed, to rotate it. Following, to start the static cycle:

Set **F800=2**, press  key; The automatic process starts, „**TEST**“ shown on display, after a few seconds it will terminate; All values for rotor resistance main inductivity and leakage inductivity are stored automatically on parameters F806 to F808, **F800** will reset to 0.

F806 Stator resistance (Ohm)	Range: 0.001...65.00 Ohm	
F807 Rotor resistance (Ohm)	Range: 0.001...65.00 Ohm	
F808 Leakage inductivity (mH)	Range: 0.01...650.0 mH	
F809 Main inductivity (mH)	Range: 0.1...6500 mH	

If parameter **F801** (Motor rated power) is changed, all parameters **F806...F809** are reset to default values, a following AUTOTUNING process, as described above may used for fine tuning.

15) Parameter group 800: Autotuning – Motor data programming

Additional parameter for optional permanent magnet motor PMM control – F870, F871, F873

(F106=6) PMM control algorithm selected

<i>F870</i> Motor feed back electrical force	V/1000 rpm	
<i>F871</i> Induktivity D-axis (Ohm)		
<i>F872</i> Induktivity Q-axis (Ohm)		
<i>F873</i> Stator resistance (Ohm/Phase)		
<i>F876</i> Idling current (% rated current)		Default setting 20%
<i>F877</i> Frequency compensation idle current (%)		Default setting 0%
<i>F878</i> Threshold idle current compensation (Hz)		Default setting 10Hz%
<i>F880</i> Scan-rate controller		Default setting 0,2 sec.

16) Parametergruppe 900: RS485 Hardware und Schnittstellenparameter

Please refer on specific MODBUS manual, for protocol, control algorithm, control registers, and other details

F900 Inverter address	Selection: 1...255: fixed adress 0: adress to assigne	Default setting: 1
F901 Interface operation mode	Selection: 1: ASCII protocol 2: RTU protocol 3: Interface used for remote panel operation	Default setting: 1
F903 Parity check	Selection: 0: No check 1: ODD parity 2: EVEN parity	Default setting: 0
F904 Baudrate	Selection: 0: 1200 1: 2400 2: 4800 3: 9600 4: 19200 5: 8400 6: 57600	Default setting: 3
F905 MODBUS Time-out	Range: 0.0.....3000 sec.	Default: 0,0 sec

F905: Modbus Timeout: To stop the system, in case, modbus command is missing within the timeframe, set in **F905**. **CE** on the display shows MODBUS time-out

F905=0: Timeout-protection deactivated

A baudrate of 9600 is recommended for reliable communication

Hardware MODBUS connection:

Inverter up to 22 kW Size E1-E6:

TA	TB	TC	DO1	24V	CM	OP1	OP2	OP3	OP4	OP5	10V	AI1	AI2	GND	AO1	A+	B-
----	----	----	-----	-----	----	-----	-----	-----	-----	-----	-----	-----	-----	-----	-----	----	----

Inverter above 22 kW Size C3-C6:

TA	TB	TC	DO1	DO2	24V	CM	OP1	OP2	OP3	OP4	OP5	OP6	OP7	OP8	10V	AI1	AI2	GND	AO1	AO2	A+	B-
----	----	----	-----	-----	-----	----	-----	-----	-----	-----	-----	-----	-----	-----	-----	-----	-----	-----	-----	-----	----	----

The 8-pole RJ-connector is used for the Keypad (internal/remote) (on size Size C3-C6), and for the remote keypad (on Size E1-E6). Standard network cable, max. lenght 10m, is suitable to connect the remote keypad

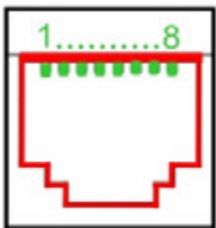

Pins	1	2	3	4	5	6	7	8
SIGNAL	Poti	5V	GND	GND	Signal	Signal	Signal	Signal

17) Parameter group A00: PID controller parameter

Integrated PID-controller

An integrated PID-controller is available on standard E800 inverters. It is suitable for simple closed loop control projects.

Controller configuration for set-point and feed-back channel (see graphic on following page)

FA01 PID set-point channel	Selection: 0: internal reference (value in FA04) 1: Analogue input AI1 2: Analogue input AI2	Default setting: 0
-----------------------------------	--	--------------------

FA02 PID feed-back channel	Selection: 1: Analogue input AI1 2: Analogue input AI2	Default setting: 1
-----------------------------------	---	--------------------

Controller limits

FA03 Upper controller limit (% of set-point)	Range: 0.0...100.0 %	Default setting: 100.0
FA04 Internal set-point value (%)	Range: 10.0...100.0%	Default setting: 50.0
FA05 Lower controller limit (% of set-point)	Range: 0.0...100.0%	Default setting: 0.0

If the controller works beyond the limits in **FA03** - **FA05** inverter will be disabled, **(nP)** on display

Polarity

FA06 PID controller polarity	Selection: 0: Positive 1: Negative	Default setting: 1
-------------------------------------	---------------------------------------	--------------------

Sleep mode

FA07 Automatic sleep mode	Selection: 0: activated 1: deactivated	Default setting: 1
FA09 Frequency threshold for sleep mode activation	Range: between F112...F111	Default setting: 5.00 Hz
FA10 Time delay for sleep mode activation (sec.)	Range: 0...500 sec.	Default setting: 15 sec.

If the inverter runs for a programmed time, (set by **FA10**) below the minimum frequency, (set by **FA09**), it will stop and enter in sleep mode, displayed as **nP**. (feed-back value must stay within programmed limits **FA03-FA04**).

FA11 Delay-time for restart from sleep mode	Range: 0...3000 sec.	Default setting: 3.0 sec
--	----------------------	--------------------------

If feed back (pressure) falls below the value in (**FA05**), inverter will restart again, after the delay-time in (**FA11**) is up

FA18 Variable set-point allowed	Selection: 0: deactivated 1: activated	Default setting: 1
--	---	--------------------

If **FA18=0**: It is not possible, to change the fixed set-point in (**FA04**) during controller operation

PID controller structure

E800 - CONTROLLER BLOC DIAGRAM

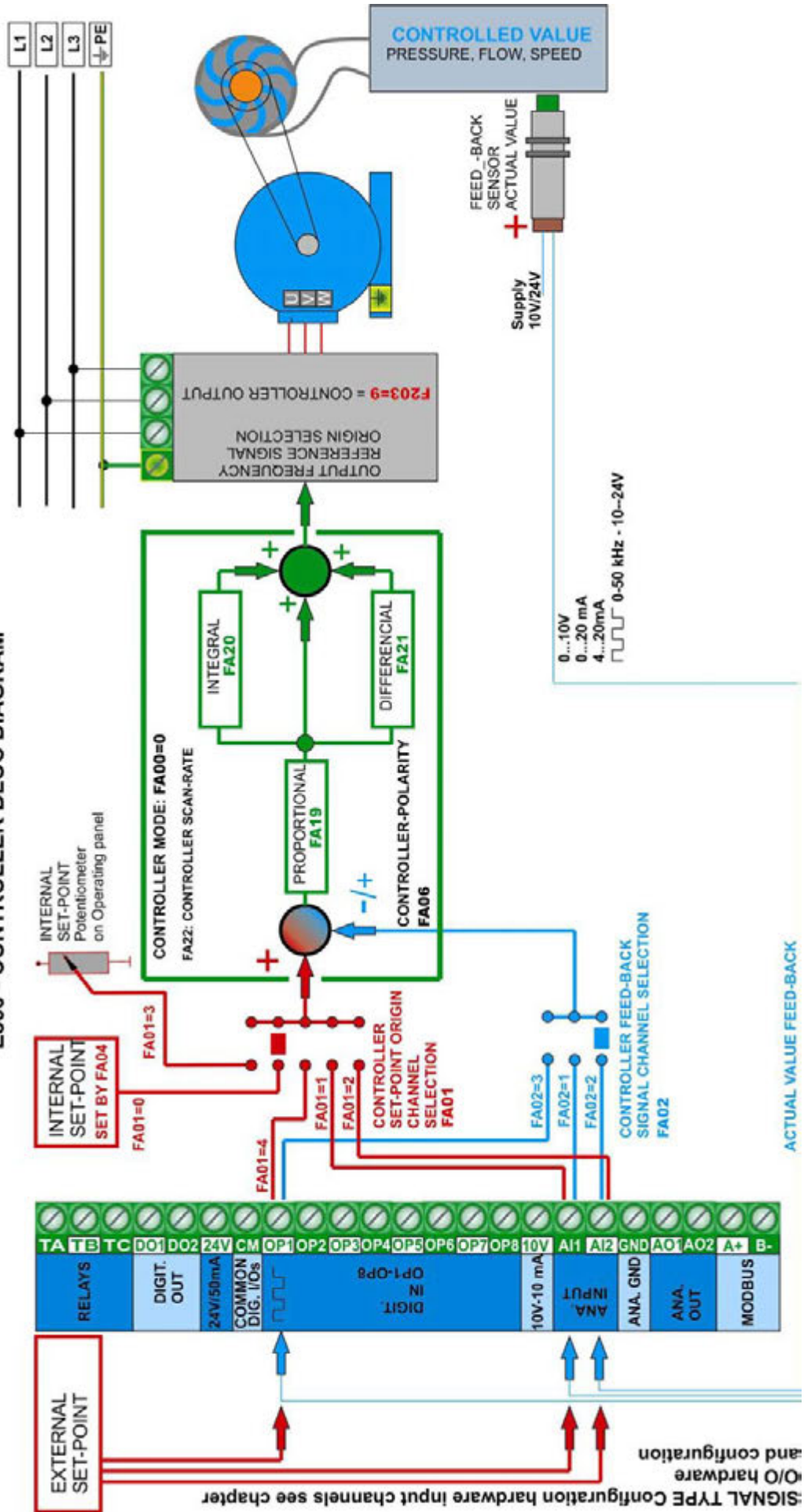

17) Parameter group A00: PID controller parameter

PID controller parameter setting

FA19 Proportional gain P	Range: 0.00...10.00	Default setting: 0.3
FA20 Integration time I (sec.)	Range: 0.1...100.0 sec.	Default setting: 0.3 sec.
FA21 Differential time D (sec.)	Range: 0.00...10.00	Default setting: 0.0 sec.
FA22 Controller cycle time / scan-rate (sec.)	Range: 0.1...10.0 sec.	Default setting: 0.1 sec.

Controller dead band +/- % of the set point

FA29 Dead band setting (% of set-point)	Range: 0.0 - 10.0 %	Default setting: 2.0
--	---------------------	----------------------

If the feed-back (actual value) stays within the dead band, the controller does not make any activity, and it keeps the output frequency constant. The FA29 parameter is used also for starting/stopping the fixed speed pump – see below

Emergency functions

FA59 Selection of different emergency functions	Selection: 0: no function selected 1: FIREMODE 1 2: FIREMODE 2	Default setting: 0
FA60 Frequency for emergency condition	Range F112...F111	Default setting: 50 Hz
FA58 Pressure for emergency conditions	Range 0.0....100%	Default setting: 80%

Emergency condition is triggered through specific terminal command (digital input - Dlx assignment code **33**) in this case, all protection functions are deactivated, and all auto-restart functions are activated.

FIREMODE 1 Inverter works with the regular set-point

FIREMODE 2, Inverter works with fixed frequency, set in parameter **FA60**

Emergency pressure mode is activated by terminal, digital input (Dlx assignment code **32**)

19) E800 Diagnosis

Intelligent diagnosis tools for set-up and troubleshooting.



Digital input status monitoring

<p>F330 Digital input monitor</p>	<p>The single vertical segments on the 7 segment display correspond to the DI1...DI8 input status, starting from left side for DI1. Segments flip down for activated inputs</p>
--	---



Analogue input value check

<p>F331 Analogue value on AI1</p>	<p>0...4096</p>
<p>F332 Analogue value on AI2</p>	<p>0...4096</p>
<p>F333 Analogue value on AI3</p>	<p>0...4096</p>

Digital output stimulation

<p>F335 Relais output stimulation</p>	<p>outputs are switched ON/OFF, using   keys</p>
<p>F336 Digital output DO1 stimulation</p>	
<p>F337 Digital output DO2 stimulation</p>	

Analogue output stimulation

<p>F338 Stimulation of analogue output AO1</p>	<p>The signal of the analogue outputs can be set from 0...100% (0...4096), using   keys</p>
<p>F339 Stimulation of analogue output AO2</p>	

The logo consists of the letters 'BLU' in a bold, blue, sans-serif font. The 'B' and 'L' are connected at the bottom, and the 'U' is slightly taller than the 'L'.

BLU

BLU S.r.l.

Via dell'Artigianato , 37 30030 VIGONOVO (VE)

Ph. +39 049 9800318 Fax. +30 049 9800319

Email: info@bludrive.it Web : www.bludrive.it