

E2000 - EP66 - EM30

USER MANUAL

FOR PUMP CONTROL

*Safety instructions Installation
& operating manual*



BLU S.r.l.

Via dell'Artigianato , 37 30030 VIGONOVO (VE)
Ph. +39 049 9800318 Fax. +30 049 9800319
Email: info@bludrive.it Web : www.bludrive.it

ENGLISH

Page : 1 to 80
Multimaster Pump Control_V-1.2

Index for this user manual

I.- Purpose of the manual and revision history	4
II.- Glossary and warnings.....	4
II.a.- Glossary of abbreviations used in this manual	4
II.b.- Icons for notes, important information or warnings.....	4
II.c.- Security warnings.....	4
II.d.- Recommendation for commissioning.....	4
II.d1- Return the inverter to its default factory settings	5
II.d2- Motor autotuning.....	5
III.- Development of the parameter selection menu.....	6
1.- Simple pump.....	7
1.1.- Simple control mode.....	7
1.2.- Level control mode.....	8
1.3.- Pressure empty mode.....	9
1.3.a.- Change of sensor for the PID.....	10
1.4.- Well pumps mode.....	11
1.5.- Solar limitation mode.....	13
1.6.- Fire-fighting mode.....	18
1.6.a.- Jockey pump.....	19
1.6.b.- Fire-fighting pump.....	20
2.- Regulated + fixed.....	21
2.1.- Regulated + fixed WITHOUT rotation	22
2.2.- Regulated + fixed, rotation by time of use.....	23
2.3.- Regulated + fixed, rotation after falling asleep the regulated	24
3.- All regulated	25
3.a.- Connection for communications	26
3.b.- Automatic synchronization	26
3.b.1- Initial synchronization to the commissioning	27
3.b.2- Synchronization after adding a inverter to the chain	28
3.b.3- Synchronized parameters	29
3.1.- Multi-master fixed	30
3.2.- Multi-master rotation by time of use of the Master.....	31
3.3.- Multi-master rotation after falling asleep the Master	32
4.- Auxiliary and protection functions	33
4.1.- Protection functions	33
4.1.a.- Protection of access to the Pump Control	33
4.1.b.- Anti-jam function.....	34
4.1.c.- Leak detection	36
4.1.d.- Dry running	37
4.1.e.- Filling of the installation.....	38
4.2.- Auxiliary functions	39
4.2.a.- Water flow detection	39
4.2.b.- Cleaning of the pump	40
4.2.c.- MANUAL / AUTOMATIC control	41
4.2.d.- Anti-rust/Anti-freeze.....	43

4.2.e.- Timer.....	44
4.2.f.- Solar/well pump autotuning	46
4.2.g.- Anti-return valve control	47
4.2.h.- Flow meter	48
4.2.i.- User macros	49
4.3.- Control modes.....	50
4.3.a.- SP Adjustable by impulses of DI inputs	50
4.3.b.- Multiple SP	50
4.4.- Dead band compensation	50
4.5.- Avoid "water hammer"	51
5.- Pump Control Menu: Parameter list: I / O Configuration	52
6.- Pump Control Menu: Parameter List: PID Configuration	55
7.- Pump Control Menu: Parameter list: Control regulation	58
8.- List of alarms	62
9.- Observations for optimal running	64
9.1.- The process units and PID	64
9.2.- Acceleration and deceleration	65
9.3.- Activation of auxiliary pumps (fixed or regulated)	66
9.4.- Deactivation of fixed auxiliary pumps	67
9.5.- Deactivation of regulated auxiliary pumps	68
9.6.- Automatic restart after voltage failures	69
9.7.- Auto-reset of the inverter alarms	70
9.7.a.- Auto-reset LU alarm.....	71
9.7.a1.- Normal Auto-reset LU	71
9.7.a2.- Auto-reset of LU in "Solar limitation" mode	72
9.8.- Supervision of the analogic signal	73
9.7.a2.- Auto-reset of LU in "Solar limitation" mode	73
PERSONAL NOTES:.....	74
PERSONAL NOTES:.....	75
PERSONAL NOTES:.....	76
PERSONAL NOTES:.....	77
PERSONAL NOTES:.....	78
PERSONAL NOTES:.....	79

I.- Purpose of the manual and revision history

This manual is intended for the specialist technician in pump installations, and wants to be a complementary help for the commissioning of your installation. It is assumed, to the technician, the judgment of knowing which pumping system and which functions are the most adequate for the purpose pursued in your station or pumping group.

The updates history of this manual is shown in the following table:





<i>Date</i>	<i>Version</i>	<i>Detailed description</i>	<i>Author</i>
05/04/2019	1.0	Official version for pumping system, with all the operating modes for pumps, special parameters and explanatory charts.	MPR
23/04/2019	1.1	Correction of minor errors of version 1.0	MPR
15/07/2019	1.2	Minor corrections, extension of the solar mode and new functions	MPR

II.- Glossary and warnings

II.a.- Glossary of abbreviations used in this manual

<i>SP</i>	<u>S</u> et <u>P</u> oint	<i>PV</i>	<u>P</u> rocess <u>V</u> alue
<i>PID</i>	<u>P</u> roportional, <u>I</u> ntegral and <u>D</u> erivative control algorithm used in the regulation loop.		Indicates the text that will be displayed on the multimedia keypad of the EP66 or EM30 inverters. Any of them can be used with E2000/E2100 .
<i>PLC</i>	<u>P</u> rogrammable <u>L</u> ogic <u>C</u> ontroller	<i>RTC</i>	<u>R</u> eal <u>T</u> ime <u>C</u> lock

II.b.- Icons for notes, important information or warnings

	Return to the index. This manual is specially designed <u>thinking about its electronic use</u> , from a <i>tablet</i> or a <i>PC</i> . This help, located at the bottom of the page, offers the possibility of always returning to the index of this manual.
	Information, note of important information to take into account. It does not necessarily generate malfunctions, it does not entail significant risk.
	Important information to respect. Malfunctions can occur that not involve significant risks.
	Warning to respect. Situations that generates breaks or damages and/or carry significant risks can occur.

II.c.- Security warnings

This manual does not describe or insert any safety warning for the connection or electrical environment. All of them correspond to the installation and commissioning of the inverters or the pumps, and they are perfectly detailed in the corresponding manual.

II.d.- Recommendation for commissioning

It is recommended to initially return the device to its default factory values and to match the inverter with its motor by performing the appropriate autotuning, before any parameterization procedure and especially if you have doubts that the inverter has been previously programmed for other tasks. Both procedures are described below

II.d1- Return the inverter to its default factory settings

If you want to recover the default factory values of the inverter, use this parameter:

Param.	Display / Use	Options/Range	Def.
F160	 : Default RESET Reverting to manufacturer values	0 : Normal Operation 1 : Factory Parameters	0

Procedure for resetting factory parameters:

Select parameter **F160**, press [SET], the original parameter **F160** value is 0, press the key  to set **F160**=1 press [SET] again.

After a few seconds all the factory default parameters are restored.





The value in **F160** return to 0, after the restoration process has been completed.

	ATTENTION: The process will not restore the default factory values in the following parameters: F400, F402, F406, F408, F412, F414, F421, F732, F742, F745, F901
---	--

II.d2- Motor autotuning

If you want to carry out the autotuning of the motor, follow these steps carefully.

Set the parameters **F801** to **F810** with the values of **THE MOTOR PLATE**.

Param.	Display / Use	Options/Range	Def.
F801	 : Motor rated power Rated power on the motor plate (kW)	0.2 ~ 1000 kW	0
F802	 : Motor rated voltage Rated voltage on the motor plate (V)	1 ~ 440 V	
F803	 : Motor rated current Rated current on the motor plate (A)	0.1 ~ 6500 A	
F805	 : Motor rated rpm Rated speed on the motor plate (RPM)	1 ~ 30000 U/min	1500 RPM
F810	 : Motor rated frequency Rated motor frequency (Hz)	1.0 ~ 300.0 Hz	50,00 Hz

When you have adjusted all the previous parameters, change this parameter:

Param.	Display / Use	Options/Range	Def.
F800	 : AUTOTUNING Mode Selection measured from motor data (AUTOTUNING)	0 : AUTOTUNING deactivated 1 : START AUTOTUNING dynamic 2 : START AUTOTUNING static	0

Set **F800**=1, if the motor can turn when doing the autotuning or **F800**=2 if it is coupled to the machine and it can not turn.

After saving the value, press [RUN] on the keypad.

For a few seconds the display will show **TEST** and at the end the autotuning **F800** will return to 0 and **TEST** will disappear from the display.

The inverter is parameterized with the values of the connected motor. (You can redo the autotuning whenever you want)

	IMPORTANT: Take into account the previous value of F724 if you want to carry out the pump autotuning with the inverter powered by solar energy. See 1.5.- Solar limitation mode
---	---

III.- Development of the parameter selection menu

The structure of the pumping menu follows the following flow diagram.

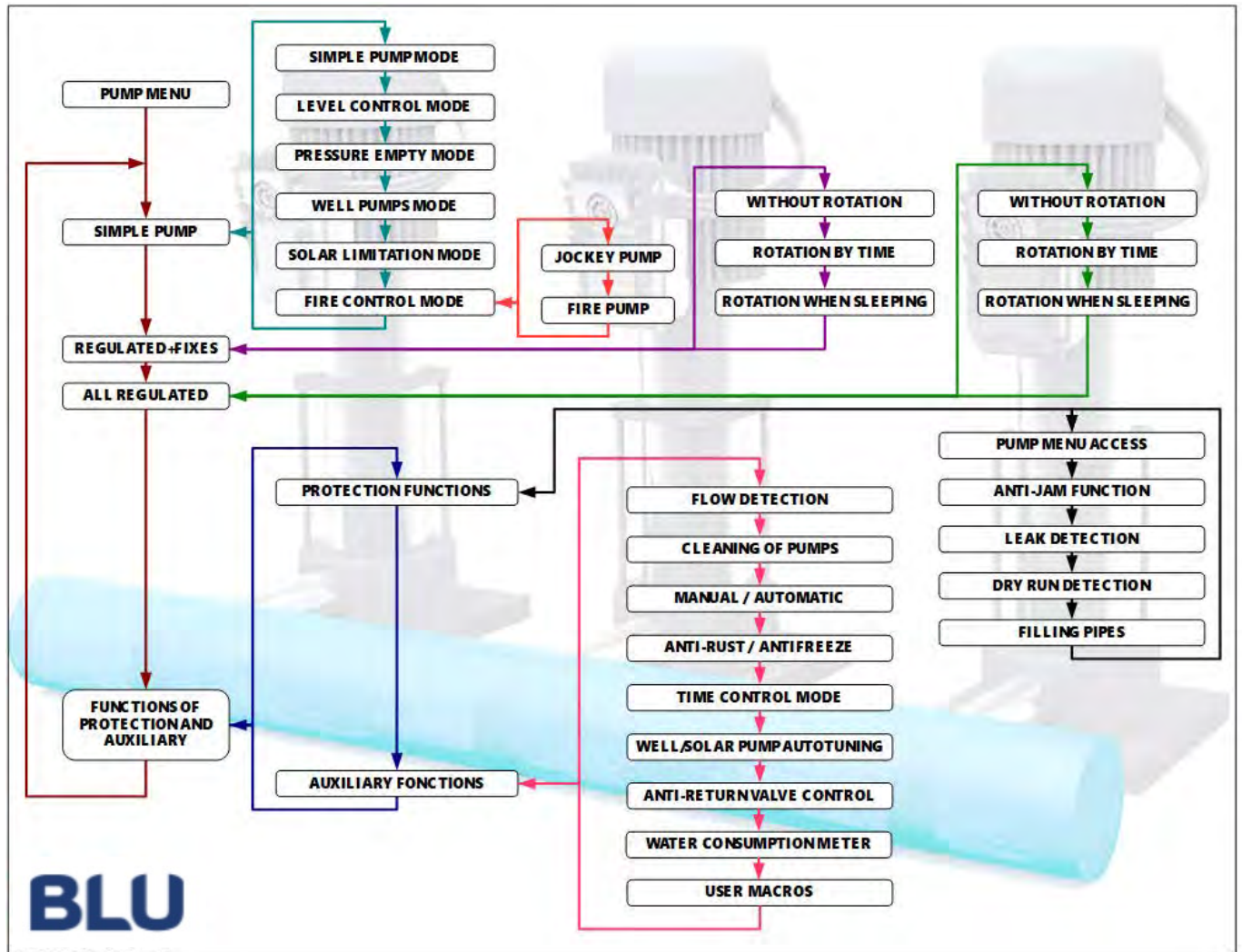

The description of the functions developed in this menu are detailed below in the different sections of this manual.

	<p>ATTENTION:</p> <p>Although in principle the program is the same for all inverter series BLU there is peculiarities that stand out from one series on the other. These particularities are specifically indicated in each paragraph.</p>
---	---

1.- Simple pump

The pumping control mode for a simple pump is the most commonly used in well extraction systems, simple irrigation systems, transfer between tanks, filling or emptying tanks, extraction or solar irrigation, fire fighting systems, etc...that only need to exercise the control over a pump driven by an inverter.

The control over the speed of the pump can be the result of the **PID** function or of the regulation by the arrows of the keypad or an external potentiometer.

The control modes are detailed below.

1.1.- Simple control mode



For a pump with simple operation, without any special function in addition to the “Fall asleep” and “Wake up” function, **PV** by analog sensor mA or V.

- Configure parameters in [5.- Pump Control Menu: Parameter list: I / O Configuration](#) that proceed according to the work mode.
- Configure parameters of the **PID** in [6.- Pump Control Menu: Parameter List: PID Configuration](#) that proceed according to the work mode, having special relevance those that are detailed below.

Param.	Display / Use	Options/Range	Def.
FA00	 : PID Controller mode Controller configuration	0 : Simple pumping control	0

- Configure parameters of the regulation control in [7.- Pump Control Menu: Parameter list: Control regulation](#) that proceed according to the work mode, having special relevance those that are detailed below.

Param.	Display / Use	Options/Range	Def.
F203	 : Primary setpoint X Possible reference input ways of the first speed "X"	0 : Internal reference (F113) with memory 9 : PID control	0

	<p>Set F203=0, to operate the pump at a specific speed (50Hz by default). The speed is adjusted using the keys  or  on the keypad (or in F113 parameter) and it stays saved even if the inverter is turned off. If you want, you can also regulate the speed by using the keypad or an external potentiometer.</p> <p>Set F203 = 9, if the regulation is made by the PID.</p>
---	---

1.2.- Level control mode

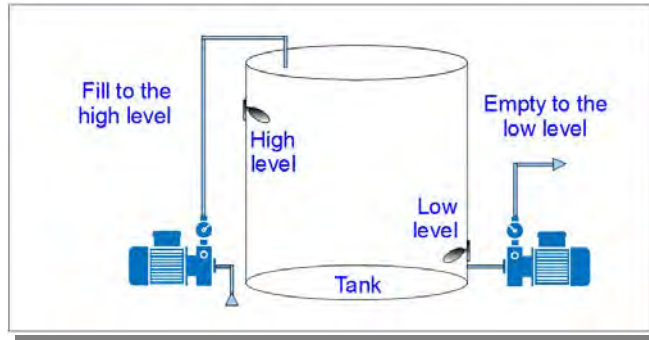

For a pump that does not use pressure sensor, but level sensor (minimum or maximum) as the only limitation of operator.







- Configure parameters in [5.- Pump Control Menu: Parameter list: I / O Configuration](#), paying special attention to the particular parameters for this mode that are indicated below:

Param.	Display / Use	Options/Range	Def.
F316 ~ F321 (F323)	 : Dlx func. assignment Configure Dlx for the desired states	71 : Filling 72 : Emptying 73 : HIGH entry level 74 : LOW entry level	See paragr. 5

- Configure parameters in [7.- Pump Control Menu: Parameter list: Control regulation](#)
The particular parameters for this mode are indicated below:

Param.	Display / Use	Options/Range	Def.
FA96	 : Level Control Activation of the mode: Level control	0 : Disabled 1 : Enabled	0
F203	 : Primary setpoint X Possible reference input ways of the first speed "X"	0 : Internal reference (F113) with memory	0

	Set F203=0, to fill/empty a tank at a certain speed (50Hz by default). The speed is adjusted using the keys  or  on the keypad (or in F113 parameter) and it stays saved even if the inverter is turned off. If you want, you can also regulate the speed by using the keypad or an external potentiometer.
	Set F203 = 9, to empty a tank at a certain pressure set by a pressure transmitter. This mode can be combined with the well pumping mode (see 1.4.- Well pumps mode) or with the pump mode with solar limitation (see 1.5.- Solar limitation mode).
	The parameters of 6.- Pump Control Menu: Parameter List: PID Configuration will not be required. However, if they have been programmed previously, for other functions, they may interfere with the level control, for example to define the speed of the pump. It is recommended to reset the default factory values (F160=1) before adjusting this control mode.

1.3.- Pressure empty mode

The layout of the installation is as shown in the image below.

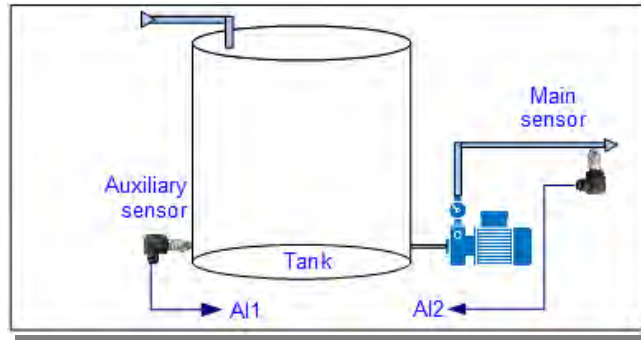

To use this working mode, two sensors must be used. The input sensor (auxiliary) measures tank pressure. The output sensor (main) measures the pressure demanded in the installation.

If *AI1* detects that there is not enough water, the pump will stop. If there is enough water, it will allow the operation of the pump.

1) When $PV < FA52$ at the auxiliary sensor, after the time **FA54**, there is not enough water, the pump stops and runs "EP5"

2) When $PV > FA51$ at the auxiliary sensor, after the time **FA53**, there is enough water, the pump starts running.

The regulation of the pump will be carried out by measuring the output pressure of the main sensor located at the output (*AI2*)











- Configure parameters in [5.- Pump Control Menu: Parameter list: I / O Configuration](#). There are no special parameters for this mode.
- Configure parameters of the *PID* in [6.- Pump Control Menu: Parameter List: PID Configuration](#), paying special attention to the **note (b)** of this paragraph.
The particular parameters of the *PID* are indicated below:

Param.	Display / Use	Options/Range	Def.
FA13	: Auxiliar.Press.Source Origin for the auxiliary pressure sensor (input)	0 : Deactivated/ no sensor 1 : Sensor connected to <i>AI1</i> 2 : Sensor connected to <i>AI2</i>	0
FA49	: Auxillar.Press.Range Auxiliary pressure sensor range (input)	0,00 ~ 10,00 Bar NOTE: Bar is the default unit; it can be changed in FA34 .	2,50 Bar
FA51	: Press. threshold IN 1 Auxiliary sensor pressure threshold (input)	FA52 ~ FA49	
FA52	: Press. threshold IN 2 Main sensor pressure threshold (output)	0,0 ~ FA51	
FA53	: Delay 1 Supervision time to restart the pump	0,0 ~ 60,0 seconds	0,0 sec.
FA54	: Delay 2 Supervision time to stop the pump	0,0 ~ 60,0 seconds	0,0 sec.
FA56	: Main sensor fault Activate Main sensor failure control (output)	0 : Deactivated 1 : Message. Error Aer0	0
FA57	: Auxillar.Sensor fault Activate Auxiliary sensor failure control (input)	0 : Deactivated 1 : Message. Error Aer1	0

- Configure parameters in [7.- Pump Control Menu: Parameter list: Control regulation](#), that proceed.
There are no special parameters for this mode.

1.3.a.- Change of sensor for the PID

In this pumping operation mode, it is possible to configure the change of the sensor to the one that you want to be the reference sensor for the *PID*. The parameters involved are indicated below:

Param.	Display / Use	Options/Range	Def.
FA90	 : In/Out Switchover Activation sensor change for reference <i>PV</i> of the <i>PID</i>	0 : Deactivated 1 : Activated	0
FA91	 : IN up-limit press. High pressure limit of the Auxiliary sensor (input)	FA93 ~ FA49  NOTE: Bar is the default unit; it can be changed in FA34.	2,50 Bar
FA92	 : IN switchover press. Pressure for <i>SP</i> change	FA94 ~ FA49  NOTE: Bar is the default unit; it can be changed in FA34.	0,50 Bar
FA93	 : Auxiliar.Setpoint <i>SP</i> for Auxiliary pressure (input)	FA94 ~ FA91  NOTE: Bar is the default unit; it can be changed in FA34.	1,00 Bar
FA94	 : Sleep Press.Auxiliar Input pressure to wake up	0 ~ FA93  NOTE: Bar is the default unit; it can be changed in FA34.	0,00 Bar
FA95	 : Auxiliar.PID Polarity Polarity for <i>PID</i> control over the Auxiliary sensor (input)	0 : Positive = Direct / Pressure / Filling 1 : Negative = Inverse / Empty / Emptying	0

	<p>Additional information on operation</p> <p>If FA90=1, the possibility of changing <i>PV</i> for the <i>PID</i> is activated If so: If the input sensor has $PV < FA92$, the <i>PID</i> uses the <i>PV</i> of the input sensor (Auxiliary) If the input sensor has $PV > FA93$, el <i>PID</i> uses the <i>PV</i> of the output sensor (Main)</p>
---	---

1.4.- Well pumps mode

For well pumps the following parameters are very important:

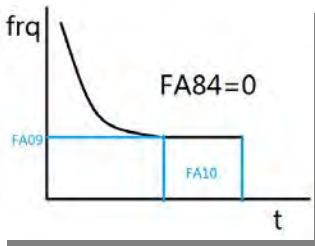

With **FA07**= 0, the "sleep" mode is enabled.

With **FA84**= 0, if the pump operates at frequency **FA09** for a period of time setting in **FA10**, the inverter will stop the pump, but it will be stay watching out the pressure mode ("Sleep" mode).

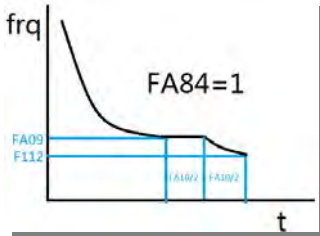

With **FA84**=1, if the pump operates at frequency **FA09** during a HALF of the time period setting in **FA10**, the inverter will lower the frequency to **F112** during a HALF of the time period setting in **FA10**, after which it will stop the pump, but it will be stay watching out the pressure mode ("Sleep" mode).

The choice of one mode or another to fall asleep depends on the height of the column of water in the outlet pipe, and of the protection that you want to make on the anti-return valve at the outlet of the pump.











ATTENTION!! This control mode varies depending on whether the anti-return valve watching out mode. See [4.2.g.- Anti-return valve control](#).

- Configure parameter in [5.- Pump Control Menu: Parameter list: I / O Configuration](#)
There are no special parameters for this mode.
- Configure parameters of the **PID** in [6.- Pump Control Menu: Parameter List: PID Configuration](#)
The particular parameters of the **PID** for this mode are indicated below:

Param.	Display / Use	Options/Range	Def.
FB43	: Well pump mode Enable well mode	0 : Activated 1 : Deactivated	0
FA07	: Sleep mode enable Automatic sleep mode	0 : Activated 1 : Deactivated	1
FA09	: Freq. threshold sleep Frequency threshold to activate function	F112~F111	5,00 Hz
FA10	: Delay-time sleep Delay for the Sleep function	0...500 seconds	15 sec.
FA84	: PID sleep mode Define the sleep mode in the PID	0 : Sleep in FA09 Hz in FA09 during FA10 , it falls asleep. 1 : Sleep under FA09 (F112) Hz in FA09 during a half of the time of FA10 , the frequency of the pump goes down to F112 during a half of the time of FA10 and it falls asleep.	0

- Configure parameters in [7.- Pump Control Menu: Parameter list: Control regulation](#)
The particular parameters for this mode are indicated below:

<i>Param.</i>	<i>Display / Use</i>	<i>Options/Range</i>	<i>Def.</i>
F203	 : Primary setpoint X Possible reference input ways of the first speed "X"	0 : Internal reference (F113) with memory 9 : Control PID	0

	<p>If you define F203=0, you will can control the pump at a specific speed (50Hz by default). The speed is adjusted using the keys  or  on the keypad (or in F113 parameter) and it stays saved even if the inverter is turned off. If you want, you can also regulate the speed by using the keypad or an external potentiometer.</p> <p>If you define F203=9, It means that a pressure sensor is available, and the pumps speed will be regulated by the PID controller and the pumping will be carried out keeping the SP.</p>
	<p>Short start and stop times. It is highly recommended to do short start and stop times when working with pumps submerged in wells. Times of 2 ~ 3 seconds for starting and stopping at powers below 75kW or 3 ~ 5 seconds for powers between 80 ~ 150kW are highly recommended. Therefore, revise that F114 and F115 do not contain disproportionate times, which would damage the pump motor.</p>
	<p>Special start and stop ramps. BLU provides a special ramp specially designed for well submersible pumps. Please, read carefully the paragraph 9.2.- Acceleration and deceleration of this manual.</p>
	<p>Starts/hour. It is the responsibility of the installer to limit the number of starts/hour of the pump according to the specifications of the manufacturer of the motor.</p>
	<p>Protection. It is essential to limit the voltage peaks to a maximum ramp of 500 V/μs and to a maximum tension peak of 1000 V according to EN 60034 (EN 0530 annex 2). Therefore, use filters (dV/dT, ferrites, shocks or sine waves) to reduce voltage peaks, especially when the cable length between the motor and the inverter is longer than 50m. Contact our TSS if you have any questions.</p>

1.5.- Solar limitation mode

The mode «Solar Control» takes into account the measurement made by a pyranometer or a plate solar radiation meter, connected to the input **AI1** (V/mA) or **AI2** (mA).

Pumping can be carried out with pressure control, for example for irrigation (**F203=9**) or with a fixed frequency adjustable by keypad, for example for filling a sump or tank (**F203=0**).

In the case of not using a pressure sensor, the pump will operate at the maximum speed set in the **PID** (**FA12**) control unless the solar sensor limits that speed due to the lack of sunlight. **FA09** contains the minimum working frequency setting of the pump for the "Sleep" function.

t0 : There is not enough sun, the pump does not start	t1 : Enough sun detected, the pump starts and its speed is limited by the amount of sun
t2 : There is enough sun, : <u>With pressure control</u> : The pump starts when the "falling sleep" frequency is exceeded and it is limited by the amount of sun or the maximum frequency set. : <u>Without pressure control</u> : The pump starts when the minimum frequency of the pump is exceeded, and it is limited by the amount of sun or the maximum frequency set.	t2a : If a cloud is detected, the speed of the pump is limited to the amount of sun measured.
t3 : The amount of sun declines, the speed of the pump is limited.	t4 : The amount of sun is not enough and the speed of the pump is below the frequency of "falling asleep" (with pressure control) or minimum frequency of the pump (without pressure control), the pump stops.

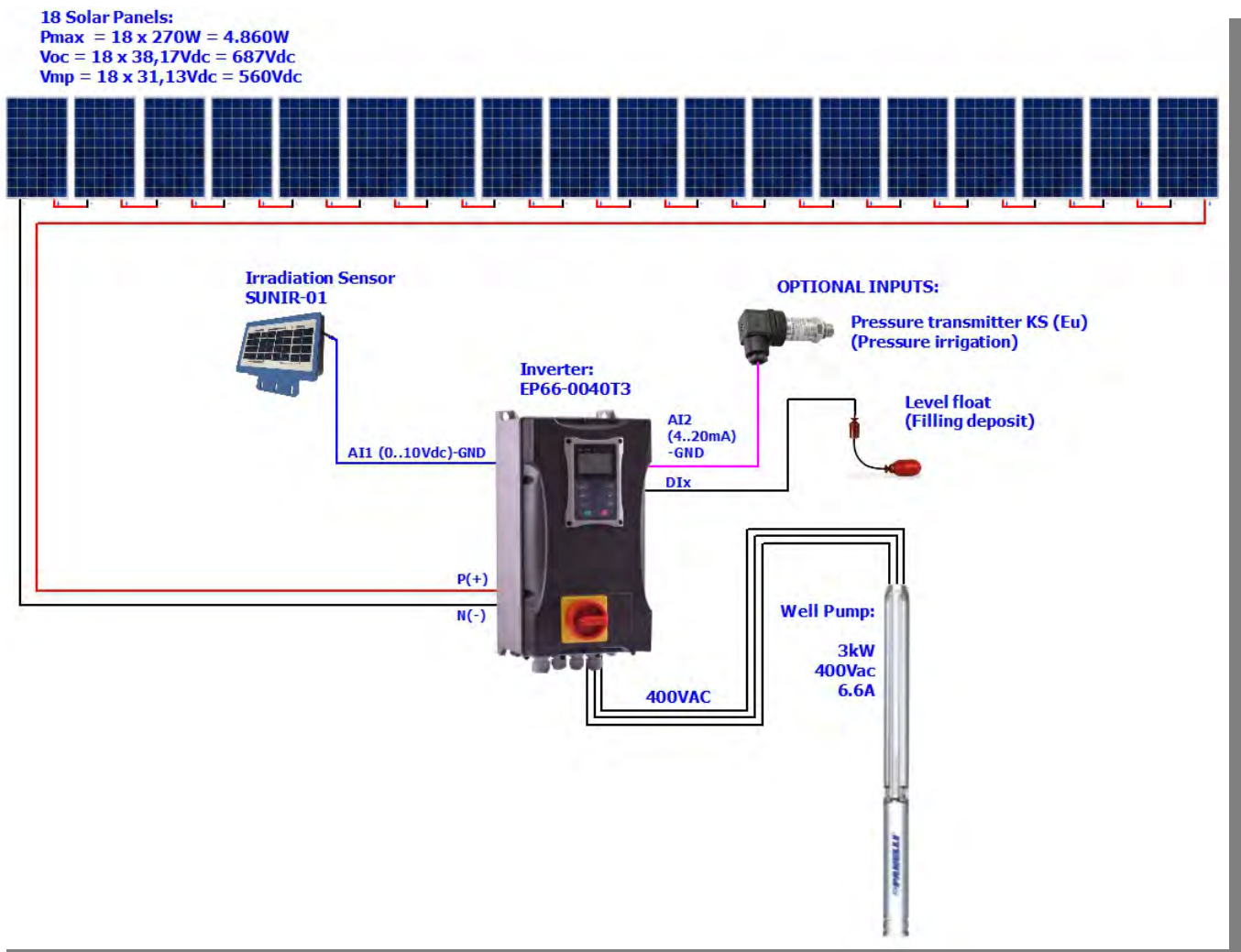

Example of a basic installation:



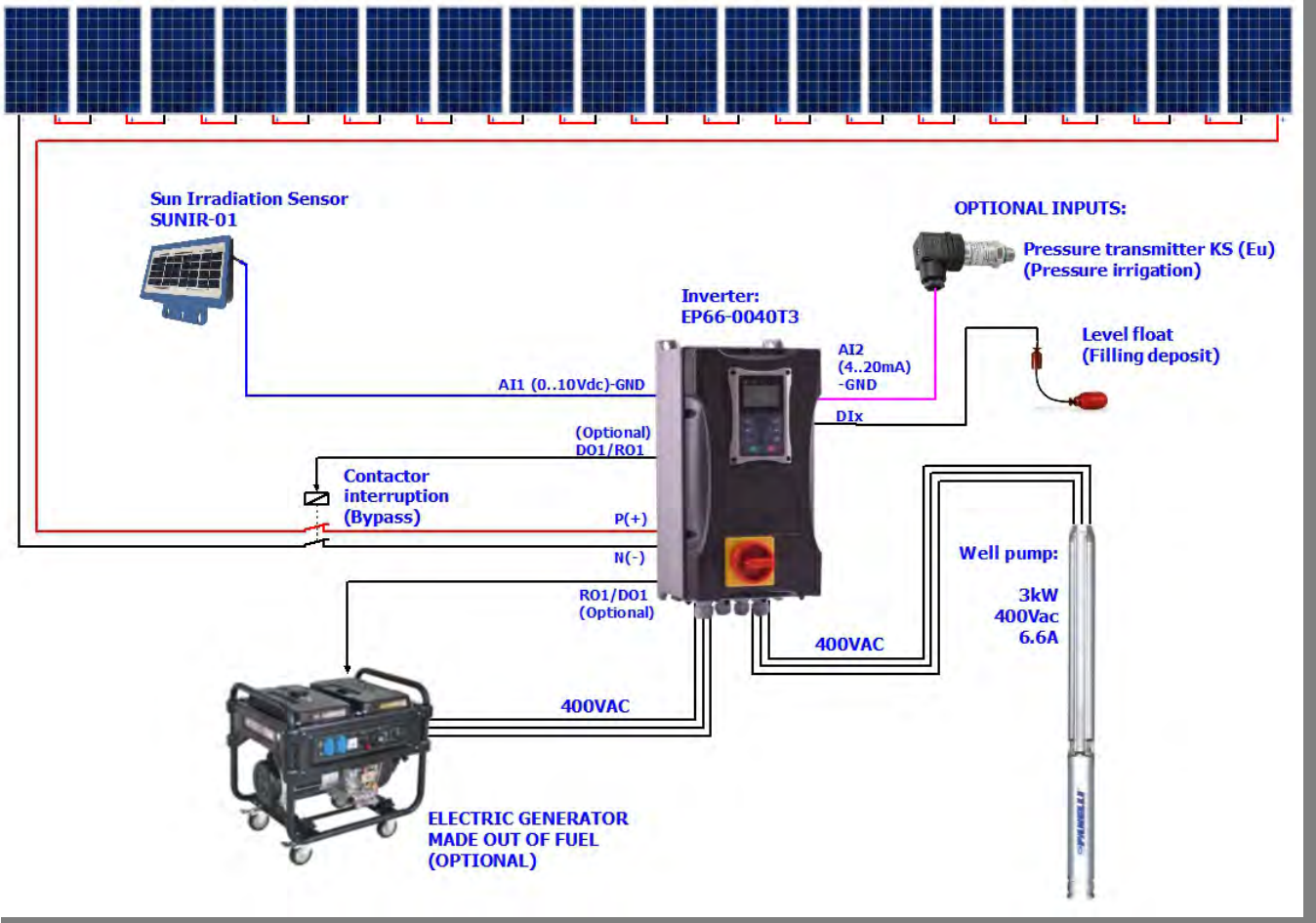

Example of a complete installation:

18 Solar Panels:
 $P_{max} = 18 \times 270W = 4.860W$
 $V_{oc} = 18 \times 38,17V_{dc} = 687V_{dc}$
 $V_{mp} = 18 \times 31,13V_{dc} = 560V_{dc}$

















	<p>Information on the power supply of the inverter by solar panels.</p> <ul style="list-style-type: none"> The single-phase inverters of the EP66 series do not have the DC bus accessible. The inverter must be powered by using L1 and L2 terminals. The E2000 series inverters below 15kW do not have the DC bus accessible. The inverter must be powered by using L1 and L2 terminals. All drives of the EM30 series have the accessible DC bus.
	<p>Information on DC supply voltage.</p> <ul style="list-style-type: none"> The supply voltage for single-phase inverters at 230Vac must be kept within the range of 260~390Vd (maximum 240~400Vdc) The supply voltage for three-phase inverters at 400Vac must be kept within the range of 350~750Vdc. (maximum 300~800Vdc)
	<p>Surveillance of phases in DC power supply.</p> <ul style="list-style-type: none"> To avoid the alarm 4: PF1 due to the lack of phase in the input (it is supplied by the DC bus or by the phases L1-L2), the supervision of input phases must be deactivated. See parameter F724 in the PID table.

- Configure parameters in [5.- Pump Control Menu: Parameter list: I / O Configuration](#)
Define if the installation works with a start/stop selector, or with push buttons to increase/decrease the *SP*, or till 4 *SP* different by *DI*'s.
If the complete installation is performed, the following functions must be adjusted.

Param.	Display / Use	Options/Range	Def.
F300	 : Rel. func. assignment Configuration of the RO1 output relay	56: Irradiation alarm (Activate the generator or the mains contactor) 57: Solar/Alternative Bypass (Deactivates the solar panels when the alternating current is stable. Delay of 15 sec. for voltage stabilization of the generator)	1
F301	 : DO1 func. assignment Configuration of the DO1 output transistor	⚠ NOTE: The bypass is optional. It is not operational if the irradiation alarm output has not been previously programmed!	14



- Configure parameters of the *PID* in [6.- Pump Control Menu: Parameter List: PID Configuration](#)
The particular parameters of the *PID* for this mode are indicated below:







Param.	Display / Use	Options/Range	Def.
FB34	 : Solar mode enable Enables speed limitation mode by solar power	0 : Disabled 1 : Enabled	0
FB35	 : Freq. limiting source Origin for speed limitation	0 : Disabled 1 : <i>AI1</i> : The radiation meter is connected to the terminal of the analog input 1 2 : <i>AI2</i> : The radiation meter is connected to the terminal of the analog input 2	0
FB33	 : Solar filtered time Stability filter for solar limitation	0,0 ~ 100,0 seconds	3,0 sec.
FB57	 : Min. Irradiation alarm Set the minimum irradiation threshold to activate the alarm output (:56 in ROx/DOx output)	0 ~ FB56	0 W/m ²
FB56	 : Minimum irradiation Minimum irradiation to start or "wake up" the pump	FB57 ~ FB55	600 W/m ²
FB55	 : Work irradiation Irradiation threshold for the pump at full working rate.	FB56 ~ FB54	1000 W/m ²
FB54	 : Full-scale sensor Full scale of the irradiation sensor	FB55 ~ 1500	1500 W/m ²
FB58	 : Total Voc Panels Total voltage of solar panels at open circuit	FB58 ~ 800	682 V.
FB59	 : Total Vmp Panels Total voltage of solar panels at maximum power	100 ~ FB57	556 V.
FB60	 : Correction factor Correction factor for the Adaptive Solar Algorithm	0,01 ~ 10,00	1,00
FB61	 : Response time Response time for Solar Adaptive Algorithm	0,001 ~ 1,000 seconds	0,001 seg.





Param.	Display / Use	Options/Range	Def.
F724	 : Inp. ph.loss monitor Protection functions: Phase loss display	0: Deactivated 1: Activated ⚠ IMPORTANT: SET TO 0 TO AVOID [4:PF1] ERROR	1
F154	 : Limit.Motor Volt. Out Compensation of the input voltage of the inverter	0: Deactivated 1: Activated 2: Disabled in deceleration ⚠ IMPORTANT: SET TO 1	0
F607	 : Limiting function Mode of activation of limitation functions	0: Disabled 1: Reserved 2: Reserved 3: Voltage / Current limitation 4: Voltage limitation 5: Current Limitation ⚠ IMPORTANT: SET TO 0	5

	<p>NOTE ABOUT PARAMETER F154 !!</p> <p>Occasionally, when the solar panels have not been dimensioned with sufficient safety margin, the inverter generates excessive low voltage faults (LU), restarting it continuously when a high frequency is reached. Parameterizing F154 = 0 can fix this circumstance, but the maximum voltage applied to the motor must be observed when the irradiation is maximum.</p> <p>It is possible that if that tension is excessively high, it will be more worthwhile to maintain F154 = 1 and extend the acceleration ramp (F114) until an adequate start is achieved.</p>
---	---

- Configure parameters in [7.- Pump Control Menu: Parameter list: Control regulation](#)
The particular parameters for this mode are indicated below:

Param.	Display / Use	Options/Range	Def.
F203	 : Primary setpoint X Possible reference input ways of the first speed "X"	0 : Internal reference (F113) with memory 9 : Control PID	0
F645	 : Main Display Display: Value to represent in the <u>first line</u> of the auxiliary screen	36: Irradiation (Allows to visualize the measure of irradiation in W / m ²)	0

	<p>NOTE!! On multiples occasions, the pump with solar control is a well pump; therefore, the same procedure can be used to “fall sleep” (see 1.4.- Well pumps mode), with the same exceptions.</p>
	<p>NOTE!! If you want that the solar limitation system work without an irradiation sensor, you can set FB35=1 and make a cable bridge between terminals +10 and A11 of the inverter or directly set FB35=0.</p>
	<p>If you define F203=0, you will can control the pump at a specific speed (50Hz by default). The speed is adjusted using the keys  or  on the keypad (or in F113 parameter) and it stays saved even if the inverter is turned off. If you want, you can also regulate the speed by using the keypad or an external potentiometer.</p> <p>If you define F203=9, It means that a pressure sensor is available, and the pumps speed will be regulated by the PID controller and the pumping will be carried out keeping the SP.</p>
	<p>ATTENTION! This control mode varies depending on whether the anti-return valve monitoring function has been activated. See 4.2.g.- Anti-return control.</p>

	<p>Short start and stop times. It is highly recommended to do short start and stop times when working with pumps submerged in wells. Times of 2 ~ 3 seconds for starting and stopping at powers below 75kW or 3 ~ 5 seconds for powers between 80 ~ 150kW are highly recommended. Therefore, revise that F114 and F115 do not contain disproportionate times, which would damage the pump motor.</p>
	<p>Special start and stop ramps. BLU provides a special ramp specially designed for well submersible pumps. Please, read carefully the paragraph 9.2.- Acceleration and deceleration of this manual.</p>
	<p>Solar start with energy optimization. In order to not discharge the energy of the solar panels very quickly, the start is progressively carried out from A FIXED FREQUENCY OF 10Hz BELOW FA09 to the minimum frequency of the pump (FA09). F112=FA09-10 (OR LESS!) must be parameterized so that starting can be carried out.</p>
	<p>Starts/hour. It is the responsibility of the installer to limit the number of starts/hour of the pump according to the specifications of the manufacturer of the motor.</p>
	<p>Protection. It is essential to limit the voltage peaks to a maximum ramp of 500 V/μs and to a maximum tension peak of 1000 V according to EN 60034 (EN 0530 annex 2). Therefore, use filters (dV/dT, ferrites, shocks or sine waves) to reduce voltage peaks, especially when the cable length between the motor and the inverter is longer than 50m. Contact our TSS if you have any questions.</p>

1.6.- Fire-fighting mode

In the fire-fighting mode, the simple control mode include two options; The *Jockey pump* is responsible of always keeping a constant pressure in the fire-fighting pipe, and the *fire-fighting pump* itself.

It is possible to combine 1 Jockey pump with one or more fire-fighting pumps, staggered by sectors from a fire control unit or by staggered activation according to mechanical pressure switch settings.

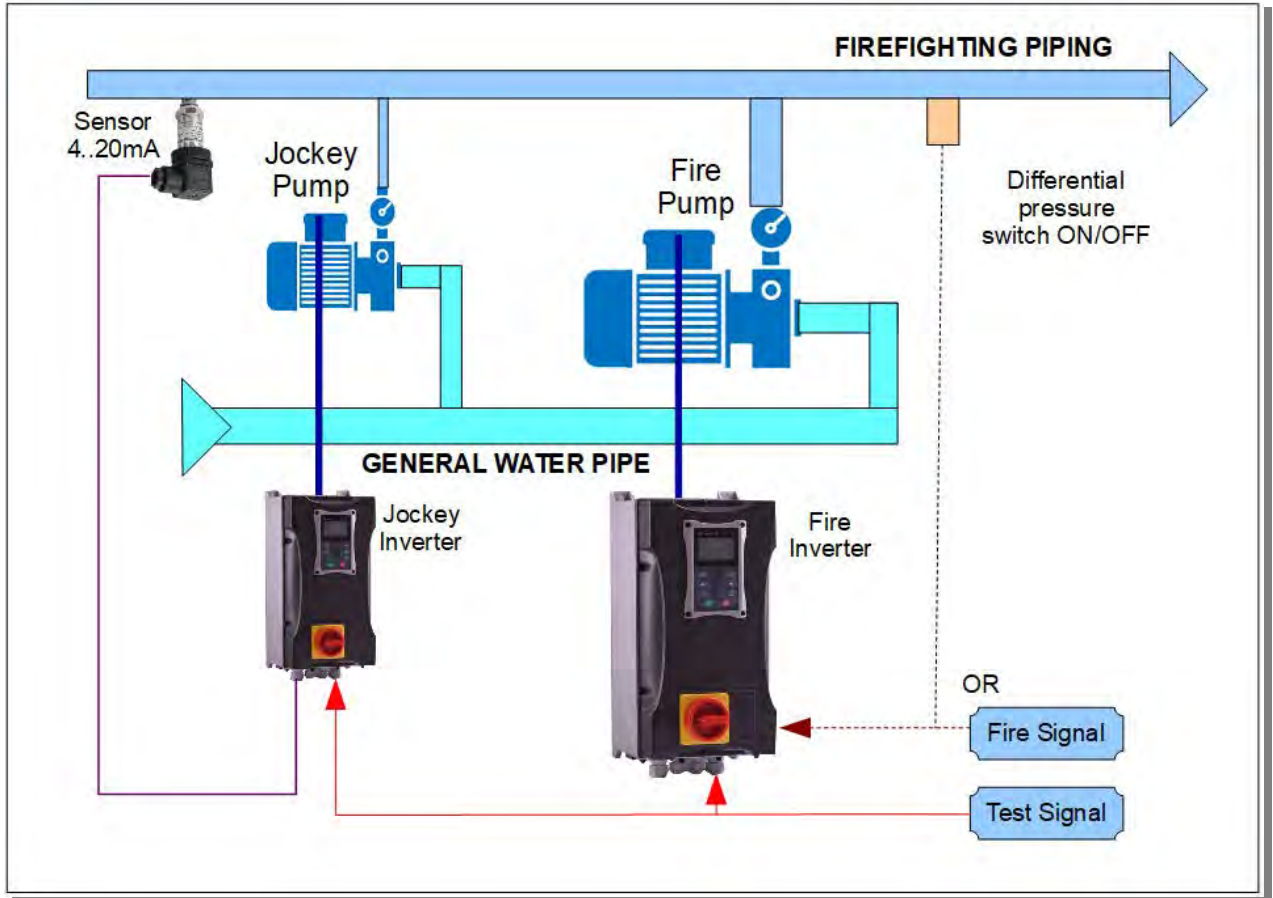





Representation of an installation with a Jockey pump and a fire pump.

1.6.a.- Jockey pump

- Configure parameter in [5.- Pump Control Menu: Parameter list: I / O Configuration](#)
The particular parameters for this mode are indicated below:

Param.	Display / Use	Options/Range	Def.
F316 ~ F321 (F323)	 : Dlx fun. assignment Configure <i>Dlx</i> for the desired states	32: Fire pressure activate 33: Fire mode activate	

- Configure parameters of the *PID* in [6.- Pump Control Menu: Parameter List: PID Configuration](#)
The particular parameters of the *PID* for this mode are indicated below:

Param.	Display / Use	Options/Range	Def.
FA58	 : FIREMODE pressure Pressure to keep in the Jockey pump	0,00 ~ 10,00 Bar  NOTE: Bar is the default unit; it can be changed in FA34.	8,00 Bar
FA89	 : Pipes charging times Jockey pump start counter	Reading only, from 0 to 50000.  READ ONLY!!! It can not be reset!	0
FA62	 : FIREMODE STOP Stop fire mode	0 : No STOP (fire-fighting mode) 1 : Manual stop (test mode)	0



- Configure parameters in [7.- Pump Control Menu: Parameter list: Control regulation](#)
There are no special parameters for this mode.

1.6.b.- Fire-fighting pump

- Configure parameter in [5.- Pump Control Menu: Parameter list: I / O Configuration](#)
The particular parameters for this mode are indicated below:

<i>Param.</i>	<i>Display / Use</i>	<i>Options/Range</i>	<i>Def.</i>
F316 ~ F321 (F323)	 : Dlx fun. assignment Configure <i>Dlx</i> for the desired states	32: Fire pressure activate 33: Fire mode activate	

- Configure parameters of the *PID* in [6.- Pump Control Menu: Parameter List: PID Configuration](#)
The particular parameters of the *PID* for this mode are indicated below:

<i>Param.</i>	<i>Display / Use</i>	<i>Options/Range</i>	<i>Def.</i>
FA59	 : FIREMODE Select the mode for fire mode	0: Disabled 1: Fire mode 1 (It operates at the maximum frequency) 2: Fire mode 2 (It operates at FA60 frequency)	1
FA60	 : FIREMODE frequency Frequency in fire mode	F112 ~ F111	50,00 Hz
FA62	 : FIREMODE STOP Stop fire mode	0 : No STOP (fire-fighting mode) 1 : Manual stop (test mode)	0

- Configure parameters in [7.- Pump Control Menu: Parameter list: Control regulation](#)
There are no special parameters for this mode.

2.- Regulated + fixed

In this operating mode, a pump is controlled by a speed variator, to which the pressure sensor is connected, controlling the auxiliary pumps (3 with **EM30**, 2 with **EP66** or **E2000/E2100**) that start the operation directly with a contactor or with soft starter.

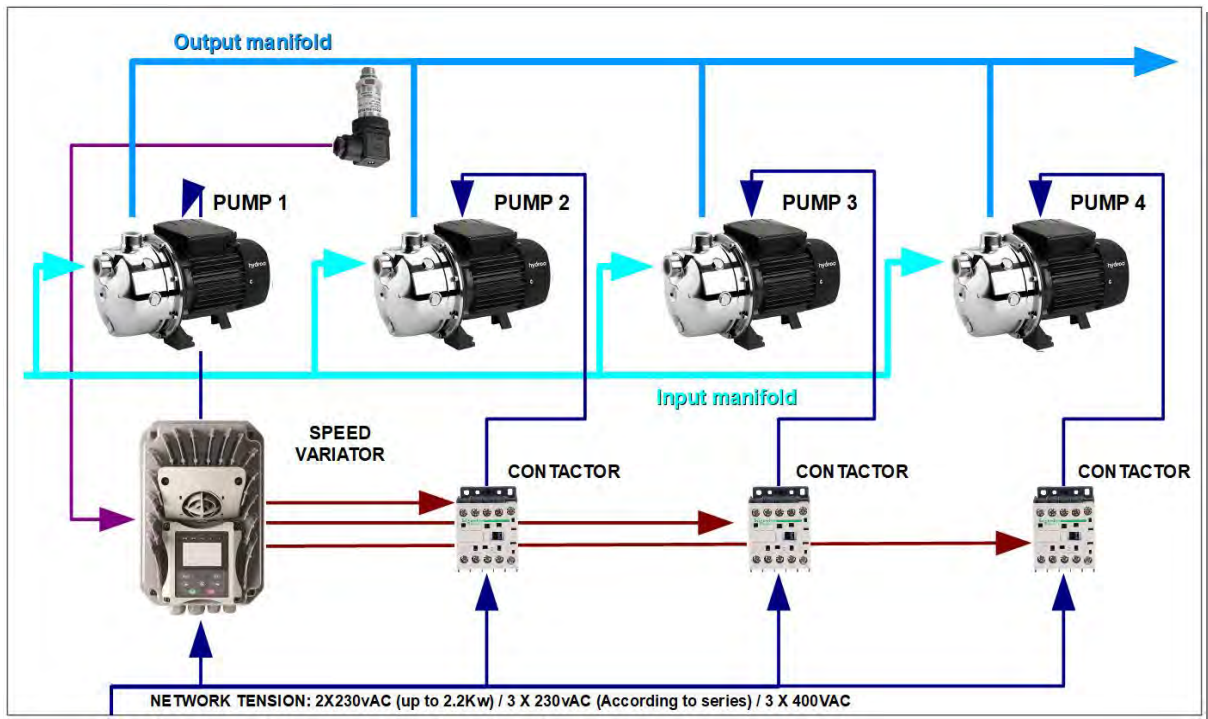

Auxiliary pumps are managed from the speed variator.

This receives the pressure signal from the sensor located in the output manifold, and modulates the speed of the pump to maintain the set pressure. In the case of needing reinforcement, the necessary relays are activated sequentially so that the pressure demanded could be regulated with the pumps that are fixed with contactor.

The installer must pay special attention to this parameter, common to all pumping regulation modes with one regulated pump and the rest of pumps fixed.

Param.	Display / Use	Options/Range	Def.
FA98	 : Interchange VFD/POWER Regulated pump stop when a fixed pump start	0 : Disabled 1 : Enabled	1

Depending on the power of the fixed pumps, it may be necessary to activate or deactivate this function.

If **FA98 = 0**, the regulated pump will not stop when a fixed pump for pressure reinforcement is connected. This can cause a significant momentary overpressure in the installation, until the regulated pump can compensate it by lowering its speed.

If **FA98 = 1**, the regulated pump will stop when a fixed pump for pressure reinforcement is connected, and it will make the **PID** control again after two seconds of the activation of the auxiliary pump

Extended information of the function is available as well as some operating graphs in paragraph [9.4.- Deactivation of fixed auxiliary pumps.](#)



IMPORTANT NOTE ABOUT THE CONFIGURATION OF RELAYS!!

In the definition of the variables, "Relay 1", "Relay 2" and "Relay 3" are indicated referring to the different contactor or starters activation outputs of the fixed pumps. These definitions correspond to the following physical outputs:

EM30: Relay 1 = DO1, Relay 2 = RO1, Relay 3 = RO2

E2000 (≤22kW): Relay 1 = DO1, Relay 2 = RO1

E2000 (≥30kW): Relay 1 = DO1, Relay 2 = RO1, Relay 3 = DO2











EP66 (≤15kW): Relay 1 = DO1, Relay 2 = RO1

EP66 (≥18.5kW): Relay 1 = DO1, Relay 2 = RO1, Relay 3 = DO2

2.1.- Regulated + fixed WITHOUT rotation

With this working mode, the rotation of the auxiliary pumps is not established, entering in operation in the same order that is established by wiring and configuration.

- Configure parameters in [5.- Pump Control Menu: Parameter list: I / O Configuration](#)
There are no special parameters for this mode.
- Configure the parameters of the *PID* in [6.- Pump Control Menu: Parameter List: PID Configuration](#)
The particular parameters of the *PID* for this mode are indicated below:













Param.	Display / Use	Options/Range	Def.
FA00	 : PID Controller mode Controller settings	1 : Regulated + fixed mode (WITHOUT <i>Slave</i> rotation)	0
FA30	 : Inv. Pump startdelay Starting delay for auxiliary pump with pump regulated at 100%	2,0 ~ 999,9 seconds	20,0 sec.
FA31	 : Pump startdelay Time with pump at 100% before timing the start of a fixed pump	0,1 ~ 999,9 seconds	30,0 sec.
FA32	 : Pump stopdelay Delay to stop a pump at the frequency of falling asleep (FA09)	0,1 ~ 999,9 seconds	30,0 sec.
FA36	 : Relays 1 Relay 1 (<i>DOI</i> in all inverter models)	0 : Not available 1 : Available	0
FA37	 : Relays 2 Relay 2 (<i>ROI</i> in all inverter models)	0 : Not available 1 : Available	0
FA82	 : Relays 3 Relay 3 (Depending on model, <i>DO2</i> or <i>RO2</i>)	0 : Not available 1 : Available	0
FA47	 : Rel. 1 Start sequence Relay 1 start sequence	1 ~ 20	20
FA48	 : Rel. 2 Start sequence Relay 2 start sequence	1 ~ 20	20
FA83	 : Rel. 3 Start sequence Relay 3 start sequence	1 ~ 20	20
FA98	 : Interchange VFD/POWER Regulated pump stop when a fixed pump start	0 : Disabled 1 : Enabled	1

- Configure parameters in [7.- Pump Control Menu: Parameter list: Control regulation](#)
There are no special parameters for this mode.

2.2.- Regulated + fixed, rotation by time of use

With this working mode, the rotation of the auxiliary pumps is established, and this is carried out after the time programmed in **FA25**. The time controlled is the operating time of the regulated pump.

- Configure parameters in [5.- Pump Control Menu: Parameter list: I / O Configuration](#)
There are no special parameters for this mode.
- Configure the parameters of the **PID** in [6.- Pump Control Menu: Parameter List: PID Configuration](#)
The particular parameters of the **PID** for this mode are indicated below:











Param.	Display / Use	Options/Range	Def.
FA00	 : PID Controller mode Controller settings	6 : Regulated + fixed mode (rotation of Slaves by time of operation)	0
FA30	 : Inv. Pump startdelay Delay to start an auxiliary pump in case of need	2,0 ~ 999,9 seconds	20,0 sec.
FA31	 : Pump startdelay Delay to start a linked pump in case of need	0,1 ~ 999,9 seconds	30,0 sec.
FA32	 : Pump stopdelay Delay to stop a linked pump if it is not necessary	0,1 ~ 999,9 seconds	30,0 sec.
FA36	 : Relays 1 Relay 1 (DOI in all inverter models)	0 : Not available 1 : Available	0
FA37	 : Relays 2 Relay 2 (ROI in all inverter models)	0 : Not available 1 : Available	0
FA82	 : Relays 3 Relay 3 (Depending on model, DO2 or RO2)	0 : Not available 1 : Available	0
FA47	 : Rel. 1 Start sequence Relay 1 start sequence	1 ~ 20	20
FA48	 : Rel. 2 Start sequence Relay 2 start sequence	1 ~ 20	20
FA83	 : Rel. 3 Start sequence Relay 3 start sequence	1 ~ 20	20
FA98	 : Interchange VFD/POWER Regulated pump stop when a fixed pump start	0 : Disabled 1 : Enabled	1
FA24	 : Time units hours/min. Unit for time control to fall asleep	0 : Hours 1 : Minutes	1
FA25	 : Switchover Interval Time for alternation	1 ~ 9999	100

- Configure parameters in [7.- Pump Control Menu: Parameter list: Control regulation](#)
There are no special parameters for this mode.

2.3.- Regulated + fixed, rotation after falling asleep the regulated

With this working mode, the rotation of the auxiliary pumps is established, and this is carried out each time that the regulated pump "sleeps".

- Configure parameters in [5.- Pump Control Menu: Parameter list: I / O Configuration](#)
There are no special parameters for this mode.
- Configure the parameters of the *PID* in [6.- Pump Control Menu: Parameter List: PID Configuration](#)
The particular parameters of the *PID* for this mode are indicated below:

<i>Param.</i>	<i>Display / Use</i>	<i>Options/Range</i>	<i>Def.</i>
FA00	 : PID Controller mode Controller settings	7 : Regulated + fixed mode (rotation of <i>Slaves</i> when the <i>Master</i> falls asleep)	0
FA30	 : Inv. Pump startdelay Starting delay for auxiliary pump with pump regulated at 100%	2,0 ~ 999,9 seconds	20,0 sec.
FA31	 : Pump startdelay Time with pump at 100% before timing the start of a fixed pump	0,1 ~ 999,9 seconds	30,0 sec.
FA32	 : Pump stopdelay Delay to stop a pump at the frequency of falling asleep (FA09)	0,1 ~ 999,9 seconds	30,0 sec.
FA36	 : Relays 1 Relay 1 (<i>DOI</i> in all inverter models)	0 : Not available 1 : Available	0
FA37	 : Relays 2 Relay 2 (<i>ROI</i> in all inverter models)	0 : Not available 1 : Available	0
FA82	 : Relays 3 Relay 3 (Depending on model, <i>DO2</i> or <i>RO2</i>)	0 : Not available 1 : Available	0
FA47	 : Rel. 1 Start sequence Relay 1 start sequence	1 ~ 20	20
FA48	 : Rel. 2 Start sequence Relay 2 start sequence	1 ~ 20	20
FA83	 : Rel. 3 Start sequence Relay 3 start sequence	1 ~ 20	20
FA98	 : Interchange VFD/POWER Regulated pump stop when a fixed pump start	0 : Disabled 1 : Enabled	1

- Configure parameters in [7.- Pump Control Menu: Parameter list: Control regulation](#)
There are no special parameters for this mode.



3.- All regulated

This is the most common method for pumps working in *Pressure Groups* also known as *Linked Pumps* or *Pump Chain*. All pumps are controlled by speed variator, and are linked or relieved to maintain the pressure of the installation in the established limits.

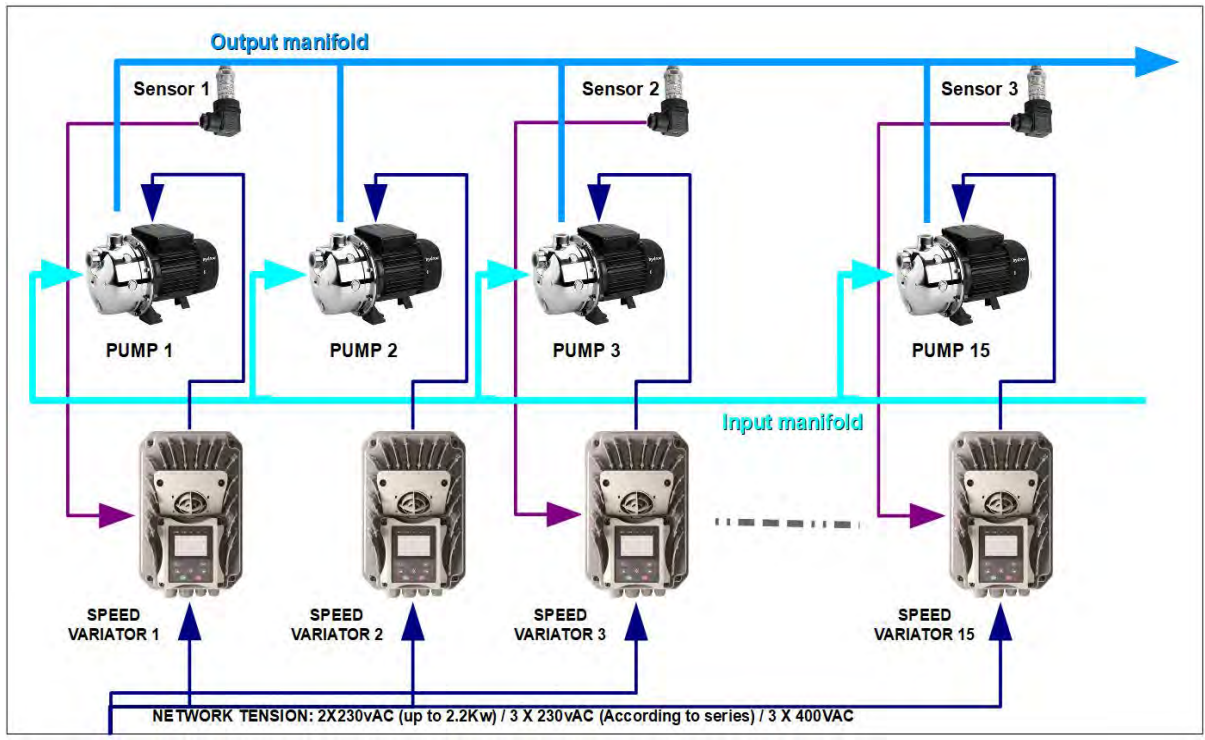
In this mode, you can have up to **15 pumps** linked in the same installation.





NOTE : The linked pumps can work in different modes. The parameter **FA34** configures the unit measurement that you want. For example; pressure (**FA34=1/2/3=Mpa/Bar/Psi**), or in level (**FA34=0/4/5=%/cm/M**) or in flow rate (**FA34=6/7=cm/sec./M/sec.**) or in heating/cooling (**FA34=8=°C**).

	<p>As you can see in the image above, it is NOT NECESSARY to place a sensor for each pump. But if it is convenient that there is more than one in the installation, to prevent the pressure group from not stopping if a sensor breaks down or if an inverter that has a pressure sensor connected is switched off.</p>
	<p>After having done the synchronization, the change of SP can be done from the keypad of any inverter of the chain. But the start and the stop of the pumping group (if this is done from the keypad) can ONLY be done from the keypad of the inverter that is <i>Master</i>.</p>

3.a.- Connection for communications

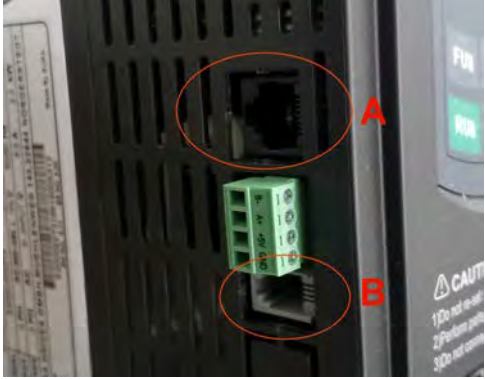
The inverters of the linked pumps that form the pressure group communicate with each other via a proprietary bus CAN (that is, it can not be managed by the installer). The communication port varies according to the inverter model and the size of these, but it is easily accessible. Some pictures are included for helping you:

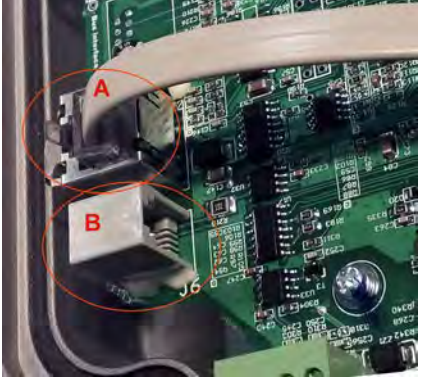
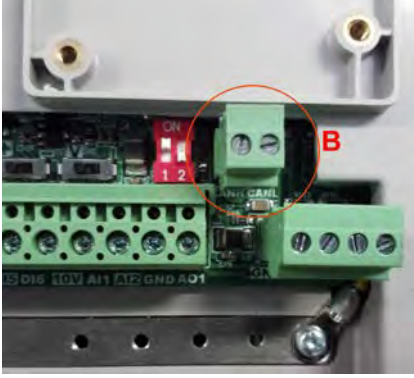
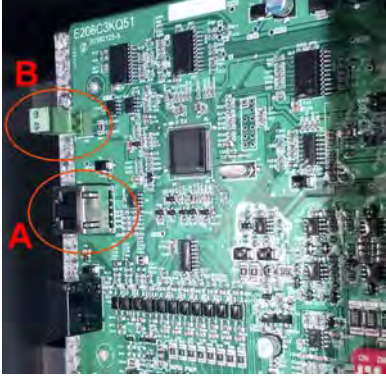
 <p style="text-align: center;">Series E2000, sizes E2 to E6</p>	<p>A = DATA port : Connection for the keypad Type 8-pin RJ45 In E2000 : for external keypad connection</p> <p>B = CAN port : Interconnection between equipment Type RJ9 (depending on the models and sizes) of 4-pin Plug-in screw connector (according to size)</p>
 <p style="text-align: center;">Series EM30 Sizes J1 and J2</p>	 <p style="text-align: center;">Series EM30 Sizes J3</p>
 <p style="text-align: center;">Series EP66 plastic cover series</p>	 <p style="text-align: center;">Series EP66 metallic cover series</p>

Therefore, the interconnection between equipment is done through a simple telephone cable pin to pin between equipment.

	<p>As a tip, due to the fragility of the telephone cable, it is advisable to protect it with an appropriate tube. It is also a good option to join all the threads of the same color, one of each cable, in an isolated terminal, and leave the four terminals of one of the inverters.</p>
---	---

3.b.- Automatic synchronization

A whole system has been developed to synchronize the settings and avoid having to repeat the same settings for all the pumps that make up the pressure group.

For example, if another pump is added to the pressure group, or if you want to set all the pumps at the same time, at the commissioning.

Two synchronization alternatives are possible and they are described in the following paragraphs.





3.b.1- Initial synchronization to the commissioning

If the entire pressure group has to be put into service at the same time, there is a very interesting procedure to gain a lot of time and not have to repeat the same programming on all the drives. The following steps must be executed:

1° : Relate the motor with the inverter:

Follow the procedure indicated in [II.d2- Motor autotuning](#) to perform the automatic calibration of the motor regulation in each pump.

2° : Parameterize the minimum synchronization values in **EACH CONVERTER**:

Param.	Display / Use
F203	 : Primary setpoint X Possible reference input ways of the first speed "X" Enter the setpoint source set in the installation (usually F203=9) (See 7.- Pump Control Menu: Parameter list: Control regulation in case of doubt)
F900	 : Inv. adress asignment Electronic address (unit number) of the inverter Enter the unit number following the last parameterized (1 ~ 15)  VERY IMPORTANT : DO NOT DUPLICATE THE ADDRESSES!!
FA00	 : PID Controller mode Controller configuration Enter the number that represents the pumping function in the chain (See 6.- Pump Control Menu: Parameter List: PID Configuration in case of doubt)



3° : Once all the inverters are parameterized properly, set the synchronization of parameters in each one (except for the one defined with **F900 = 1**).

Param.	Display / Use
FA99	 : Param. synchronizing It allows to synchronize from a <i>Slave</i> the parameters of regulation and control of the <i>Master</i> (See 3.b.3- Synchronized parameters to know the ones that are synchronized)

4° : From here, parameterize in the *Master*.

The *Master* is the one with **F900 = 1**, the display shows an **M**, in the lower left corner.

All the settings that are made in this *Master* will be automatically synchronized in the *Slaves*, the display shows an **S**, in the lower left corner.

	Warning! Not all pump parameters are synchronized. See in 3.b.3- Synchronized parameters the ones that synchronize.
	If the pump system has been configured with the <i>MANUAL / AUTO</i> function, the selector must be activating the input defined as <i>AUTO</i> .





3.b.2- Synchronization after adding a inverter to the chain

Whenever a inverter is added to a pump chain, the following steps must be followed in the new equipment:

1° : Relate the motor with the inverter:

Follow the procedure indicated in [II.d2- Motor autotuning](#) to perform the automatic calibration of the motor regulation.

2° : Parameterize the minimum synchronization values:

<i>Param.</i>	<i>Display / Use</i>
F203	 : Primary setpoint X Possible reference input ways of the first speed "X" Enter the setpoint source set in the installation (usually F203=9) (See 7.- Pump Control Menu: Parameter list: Control regulation in case of doubt)
F900	 : Inv. adress assignment Electronic address (unit number) of the inverter Enter the unit number following the last parameterized (1 ~ 15)  VERY IMPORTANT : DO NOT DUPLICATE THE ADDRESSES!!
FA00	 : PID Controller mode Controller configuration Enter the number that represents the pumping function in the chain (See 6.- Pump Control Menu: Parameter List: PID Configuration in case of doubt)
FA99	 : Param. synchronizing It allows to synchronize from a <i>Slave</i> the parameters of regulation and control of the <i>Master</i> (See 3.b.3- Synchronized parameters to know the ones that are synchronized)

3° : The added inverter will take the current values recorded in the inverter with the address **F900** = 1, and if it is not active, from the inverter acts as *Master* in the installation.

	Warning! Not all pump parameters are synchronized. See in 3.b.3- Synchronized parameters the ones that synchronize.
---	---

3.b.3- Synchronized parameters

The parameters that are automatically synchronized in all the inverters of the chain, when manually changing any of them, are the following:

PARAM.	FUNCTION	SETTING RANGE	DEFAULT SETTINGS	E2000/ E2100	EP66	EM30
F114	Acceleration ramp 1 (sec.)	0,1 – 3.000 sec.	According to inverter size	X	X	X
F115	Deceleration ramp 1 (sec.)	0,1 – 3.000 sec.	According to inverter size	X	X	X
F131	Display: Selection of the operating parameters to be displayed during the "START" status (motor running)	0 - 8192	0 + 1 + 2 + 4 + 8 = 15	X	X	X
F132	Display: Selection of the operating parameters to be displayed during the "STOP" status (motor stopped)	0 - 2048	0 + 2 + 4 = 6	X	X	X
F213	Restart after a power drop	0 - 1	0	X	X	X
F215	Restart delay after a power drop (sec.)	0,1 – 3000,0 sec.	60,0 sec.	X	X	X
F400	Range definition AI1 – Low limit (V)	0,00V – F402	0,04 V	X	X	X
F406	Range definition AI2 – Low limit (V)	0,00V – F408	0,04 V	X	X	X
F438	Input type for AI1	0 - 1	0	X	X	
F439	Input type for AI2	0 - 1	1	X	X	
F647	Change language (of the external screen)	0 - 10	0	X	X	X
FA00 ~ FA98	All pumping parameters, group A			X	X	X
FB10 ~ FB43	All pumping parameters, group B  EXCEPT FB19!!			X	X	X
FD00 ~ FD81	All pumping parameters, group D (Time control) See 4.2.e.- Timer			X	X	X

This parameter changes and is synchronized in a special way: :







PARAM.	FUNCTION	SETTING RANGE	DEFAULT SETTINGS	E2000/ E2100	EP66	EM30
FA09	Frequency threshold to activate the sleep function	F112~F111	5,00 Hz	X	X	X

If the automatic calibration of the well or solar pump has been made (see [4.2.f.- Solar/well pump autotuning](#)), the result of this autotuning is inscribed in the parameter **FA09** mentioned.

3.1.- Multi-master fixed

Select this mode if you do not want to rotate the pumps. The pump with unit number 1 will always enter the first one, and the activation and stop sequence of the installed pumps will be the one corresponding to the unit number parameterized in parameter **F900**.

- Configure parameters in [5.- Pump Control Menu: Parameter list: I / O Configuration](#)
There are no special parameters for this mode.
- Configure the parameters of the **PID** in [6.- Pump Control Menu: Parameter List: PID Configuration](#)
The particular parameters of the **PID** for this mode are indicated below:

Param.	Display / Use	Options/Range	Def.
FA00	 : PID Controller mode Controller settings	10: Multimaster fixed pumps	0
FA30	 : Inv. Pump startdelay Starting delay for auxiliary pump with pump regulated at 100%	2,0 ~ 999,9 seconds	20,0 sec.
FA31	 : Pump startdelay Time with pump at 100% before timing the start of a fixed pump	0,1 ~ 999,9 seconds	30,0 sec.
FA32	 : Pump stopdelay Delay to stop a pump at the frequency of falling asleep (FA09)	0,1 ~ 999,9 seconds	30,0 sec.
FA44	 : M/S control mode It establishes the behavior of the <i>Slave</i> with respect to the <i>Master</i> being linked	0: <i>Slave</i> Setpoint = <i>Master</i> Setpoint The <i>Slave</i> operates in a twin way to the <i>Master</i> , regulates his speed at the same time 1: <i>Slave</i> Setpoint = <i>PID</i> setpoint The <i>Slave</i> operates independently to the <i>Master</i> , <i>PID</i> regulates your speed	0
FA99	 : Param. synchronizing It allows to synchronize from a <i>Slave</i> the parameters of regulation and control of the <i>Master</i> (See 3.b.3- Synchronized parameters to know the ones that are synchronized)	0 : Disabled The <i>Slave</i> keeps its own parameters 1 : Activated The <i>Slave</i> copies the parameters of the <i>PID</i> and of the regulation of the <i>Master</i> (* See 3.b.- Automatic synchronization	0









- Configure parameters in [7.- Pump Control Menu: Parameter list: Control regulation](#)
There are no special parameters for this mode.

	If the pump system has been configured with the MANUAL / AUTO function, the rotation conditions of the function must be taken into account.
---	--

3.2.- Multi-master rotation by time of use of the *Master*

Select this mode if you wish to rotate pumps. The starting sequence of the pumps will rotate taking into account the operating time of the *Master* pump, that is, of the first pump that has entered into operation, and will transfer the *Master* function to the next available pump, according to parameter **F900**, in operation or asleep.

- Configure parameters in [5.- Pump Control Menu: Parameter list: I / O Configuration](#)
There are no special parameters for this mode.
- Configure the parameters of the *PID* in [6.- Pump Control Menu: Parameter List: PID Configuration](#)
The particular parameters of the *PID* for this mode are indicated below:

Param.	Display / Use	Options/Range	Def.
FA00	 : PID Controller mode Controller settings	11: Multimaster <i>master</i> rotation by time	0
FA30	 : Inv. Pump startdelay Starting delay for auxiliary pump with pump regulated at 100%	2,0 ~ 999,9 seconds	20,0 sec.
FA31	 : Pump startdelay Time with pump at 100% before timing the start of a fixed pump	0,1 ~ 999,9 seconds	30,0 sec.
FA32	 : Pump stopdelay Delay to stop a pump at the frequency of falling asleep (FA09)	0,1 ~ 999,9 seconds	30,0 sec.
FA44	 : M/S control mode It establishes the behavior of the <i>Slave</i> with respect to the <i>Master</i> being linked	0: <i>Slave</i> Setpoint = <i>Master</i> Setpoint The <i>Slave</i> operates in a twin way to the <i>Master</i> , regulates his speed at the same time 1: <i>Slave</i> Setpoint = <i>PID</i> setpoint The <i>Slave</i> operates independently to the <i>Master</i> , <i>PID</i> regulates your speed	0
FA99	 : Param. synchronizing It allows to synchronize from a <i>Slave</i> the parameters of regulation and control of the <i>Master</i> (See 3.b.3- Synchronized parameters to know the ones that are synchronized)	0 : Disabled The <i>Slave</i> keeps its own parameters 1 : Activated The <i>Slave</i> copies the parameters of the <i>PID</i> and of the regulation of the <i>Master</i> (* See 3.b.- Automatic synchronization)	0
FA24	 : Time units hours/min. Unit for time control to fall asleep	0 : Hours 1 : Minutes	1
FA25	 : Switchover interval Time for alternation	1 ~ 9999 seconds	100 sec.







- Configure parameters in [7.- Pump Control Menu: Parameter list: Control regulation](#)
There are no special parameters for this mode.

	If the pump system has been configured with the <i>MANUAL</i> / <i>AUTO</i> function, the rotation conditions of the function must be taken into account.
---	---

3.3.- Multi-master rotation after falling asleep the *Master*

Select this mode if you wish to rotate pumps. The starting sequence of the pumps will rotate when the *Master* pump falling sleep, that is, the first pump that has started operating, and will transfer the *Master* function to the next available pump, according to parameter **F900**, which will necessarily be **asleep**.

- Configure parameters in [5.- Pump Control Menu: Parameter list: I / O Configuration](#)
There are no special parameters for this mode.
- Configure the parameters of the *PID* in [6.- Pump Control Menu: Parameter List: PID Configuration](#)
The particular parameters of the *PID* for this mode are indicated below:

Param.	Display / Use	Options/Range	Def.
FA00	 : PID Controller mode Controller settings	12: Multimaster <i>master</i> rotation at sleep	0
FA30	 : Inv. Pump startdelay Starting delay for auxiliary pump with pump regulated at 100%	2,0 ~ 999,9 seconds	20,0 sec.
FA31	 : Pump startdelay Time with pump at 100% before timing the start of a fixed pump	0,1 ~ 999,9 seconds	30,0 sec.
FA32	 : Pump stopdelay Delay to stop a pump at the frequency of falling asleep (FA09)	0,1 ~ 999,9 seconds	30,0 sec.
FA44	 : M/S control mode It establishes the behavior of the <i>Slave</i> with respect to the <i>Master</i> being linked	0: <i>Slave</i> Setpoint = <i>Master</i> Setpoint The <i>Slave</i> operates in a twin way to the <i>Master</i> , regulates his speed at the same time 1: <i>Slave</i> Setpoint = <i>PID</i> setpoint The <i>Slave</i> operates independently to the <i>Master</i> , <i>PID</i> regulates your speed	0
FA99	 : Param. synchronizing It allows to synchronize from a <i>Slave</i> the parameters of regulation and control of the <i>Master</i> (See 3.b.3- Synchronized parameters to know the ones that are synchronized)	0 : Disabled The <i>Slave</i> keeps its own parameters 1 : Activated The <i>Slave</i> copies the parameters of the <i>PID</i> and of the regulation of the <i>Master</i> (* See 3.b.- Automatic synchronization)	0

- Configure parameters in [7.- Pump Control Menu: Parameter list: Control regulation](#)
There are no special parameters for this mode.

	If the pump system has been configured with the <i>MANUAL</i> / <i>AUTO</i> function, the rotation conditions of the function must be taken into account.
---	---

4.- Auxiliary and protection functions

4.1.- Protection functions

The protection functions are intended to perform safety supervisions on the pumping system.

Except for the access protection that is defined in paragraph [4.1.a.- Protection of access to the Pump Control](#), which allows blocking access to anyone outside the pumping system, and anti-blockage [4.1.b.- Anti-blockage function](#) that supervises the possible blockage of the pump by a solid body, the operation of the others can be summarized in the following paragraphs: The operation of the others is summarized below.

4.1.a.- Protection of access to the Pump Control

Protects access to pump parameterization.

If the value is 0, the parameterization menu of the pump control is unprotected.

With any other number previously inserted, the access will be protected, and the code must be entered to access the pump menu.



ATTENTION!! Write down the protection number when you set it, it is not possible to reset the menu if that number is forgotten

4.1.b.- Anti-jam function

This function is normally used in single-pump installations, and working with waste or fecal water.

If it is activated (**FB48** = 1), the power of the motor of the pump is monitored, the power will increase when the pump seizes up due to the obstruction of a solid body.

If the power measured in the pump (**F102**) exceeds **FB49** the supervision time **FB50**, the pump will stop during the time **FB51**, the direction of rotation will be reversed at the speed **F113** during the time **FB52**, it will stop again during the time **FB51** reversing the direction of rotation at speed **F113** during the time **FB52**.

At the end of this cycle, which is called "unblocking attempt" if the overcurrent persists, another unblocking movement will be attempted, as long as the number of attempts does not exceed those set in **FB53**. If this happens, alarm **75:ErJA** will be activated on the display and the pump will stop.

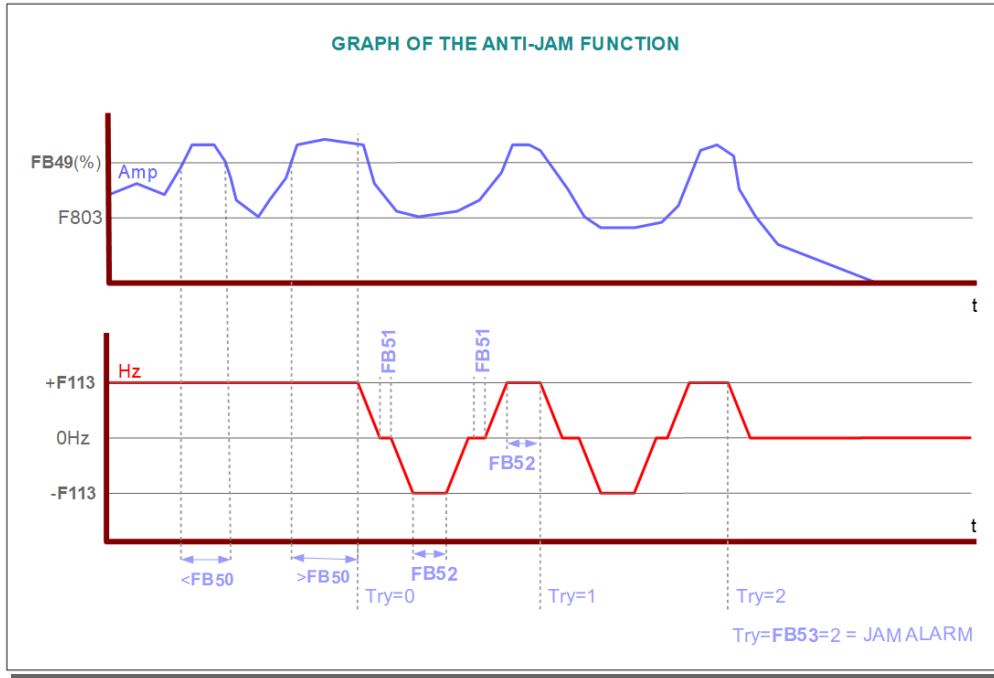

Function graph of anti-jam function.

- Configure parameters in [5.- Pump Control Menu: Parameter list: I / O Configuration](#)
There are no special parameters for this mode.
- Configure the parameters of the **PID** in [6.- Pump Control Menu: Parameter List: PID Configuration](#)
The particular parameters of the **PID** for this mode are indicated below:

Param.	Display / Use	Options/Range	Def.
FB48	: Anti-jam function Jam detection in the pump	0 : Disabled 1 : Enabled	0
FB49	: Jam overload Overload as of which it is considered a jam	100 ~ 150 % (of the power motor from F803)	115 %
FB50	: Time jam overload Jam detection time with FB49	0,1 ~ 10,0 seconds	10,0 sec.
FB51	: Time jam stopped Detection time between turning inversion	0,0 ~ 30,0 seconds	3,0 sec.
FB52	: Time jam started Operating time to unblock the jam	1,0 ~ 30,0 seconds	3,0 sec.
FB53	: Unblocking attempts Number of times the unblocking operation is done before activating the alarm	1 ~ 10 times	3

**NOTE.**

"Unblocking attempt" means the complete cycle consisting of stopping the pump by turning it in the correct direction, reversing the direction of rotation, stopping and turning again in the correct direction.

- Configure parameters in [7.- Pump Control Menu: Parameter list: Control regulation](#)
There are no special parameters for this mode.

**Additional information.**

Special attention must be paid to parameter **F203**.

If the PID (**F203=9**) is used, the speed control is determined by the reaction of the pressure measured by the installation sensor.

Normally, with sewage or wastewater, this control is not carried out in this way, but by fixed speed adjusted by keypad or communications directly on parameter **F113**.

If this is the case, put **F203 = 0**.

If the speed is adjusted by external potentiometer, for example connected to AI1, set **F203 = 1**.

4.1.c.- Leak detection

The leak detection is used to supervise the installation and generate an alarm in case of detecting a loss or lack of non-recoverable pressure. This detection is carried out at two important moments of operation; The filling, if this is activated, and in the normal regulation within the pressure cycle.

In the case of detecting lack of pressure in the installation, the system will stop immediately, activating the **alarm 69:EP6**, and **will not do the pressure recovery sequence indicated below**.

To do this, you must adjust the loss of pressure supported in a determined time and the number of retries before stopping the pump system and generate the corresponding alarm.

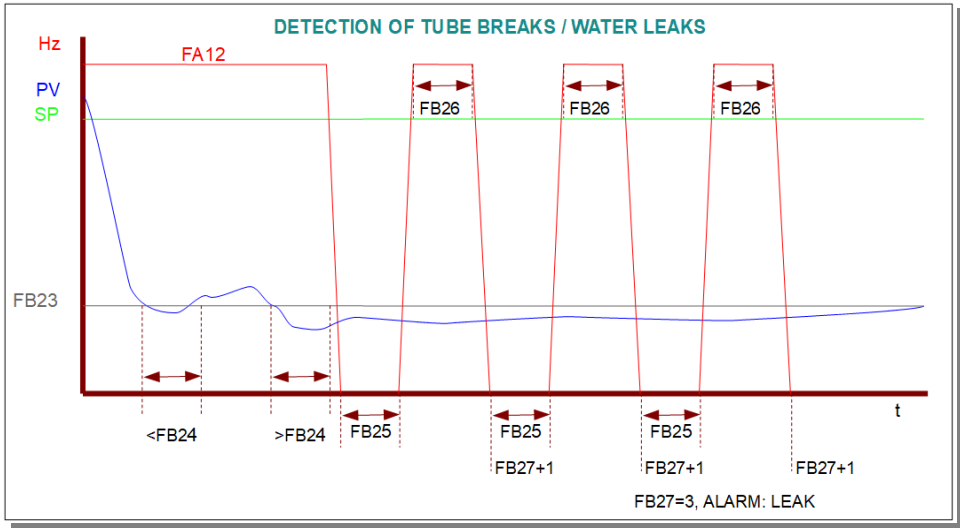

Sequence of pressure recovery before generating the **alarm 69:EP6**

Si $PV > SP$, the sequence is interrupted and regulation begins.

- Configure

parameters in [5.- Pump Control Menu: Parameter list: I / O Configuration](#)
There are no special parameters for this mode.

- Configure the parameters of the **PID** in [6.- Pump Control Menu: Parameter List: PID Configuration](#)
The particular parameters of the **PID** for this mode are indicated below:





Param.	Display / Use	Options/Range	Def.
FB23	: Leak press. detection Pressure for leak detection	FB17 ~ 80,0	0,0
FB24	: Leak detection time Detection time 1 (To pause)	0,0 ~ 300,0 seconds	5,0 sec.
FB25	: Leak detection time2 Detection time 2 (To pause)	0,0 ~ 300,0 seconds	5,0 sec.
FB26	: Leak detection time3 Detection time 3 (Running)	0,0 ~ 300,0 seconds	5,0 sec.
FB27	: Leakage det. Cycle Leak detection supervision cycles	1 ~ 10	3

- Configure parameters in [7.- Pump Control Menu: Parameter list: Control regulation](#)
There are no special parameters for this mode.

4.1.d.- Dry running

With this protection, it is possible to detect the dry running of the pump. The dry running condition can be caused by a jam in the pump's inlet pipe or manifold, or because a closed valve has been left.

- Configure parameters in [5.- Pump Control Menu: Parameter list: I / O Configuration](#)
There are no special parameters for this mode.
- Configure the parameters of the **PID** in [6.- Pump Control Menu: Parameter List: PID Configuration](#)
The particular parameters of the **PID** for this mode are indicated below:

Param.	Display / Use	Options/Range	Def.
FB16	 : Dry detection Detection of dry operation	0 : Disabled 1 : Enabled	0
FB17	 : Dry pressure Pressure for dry operation	0,0 ~ FB23	0,0 %
FB18	 : Dry delay Pressure for dry operation	0,0 ~ 300,0 seconds	60 sec.
FB19	 : Dry current threshold Current for dry operation	0,1 ~ 1000,0 A	A

- Configure parameters in [7.- Pump Control Menu: Parameter list: Control regulation](#)
There are no special parameters for this mode.

	NOTE!! Only the efficiency of the detection of dry operation in pumping groups in which all the pumps have the same inlet manifold is guaranteed.
--	--

Another effective way of detecting dry running is to provide the pump with an **NTC/PTC** temperature sensor that carries out the protection by detecting the over-temperature.

To do this, you must indicate the input used in [5.- Pump Control Menu: Parameter list: I / O Configuration](#)

Param.	Display / Use	Options/Range	Def.
F316 ~ F321 (F323)	 : Dlx fun. assignment Configure Dlx for the desired state	37 : NTC / NO 38 : PTC / NC	

4.1.e.- Filling of the installation

The filling function of the installation, if it is selected, is only active the first time the pressure group is activated, without *PV* having previously reached *SP*. In general, this happens the first time the pumping equipment is turned on and the pressure group is activated, when the pipes of the installation are discharged.

This function combines with the protection [4.1.d.- Dry running](#):

If it is activated, the operation is shown in the following graphs:

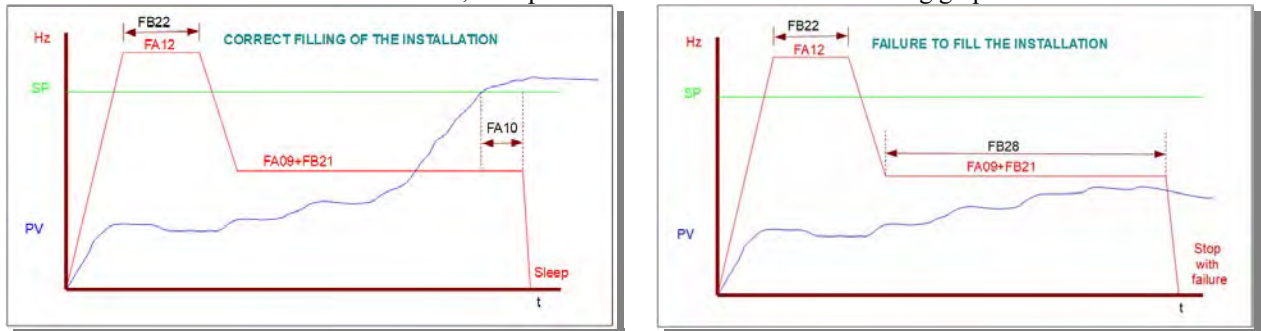

- Configure parameters in [5.- Pump Control Menu: Parameter list: I / O Configuration](#)
There are no special parameters for this mode.
- Configure the parameters of the *PID* in [6.- Pump Control Menu: Parameter List: PID Configuration](#)
The particular parameters of the *PID* for this mode are indicated below:

Param.	Display / Use	Options/Range	Def.
FB20	: Fill Installation Filling of the installation	0 : Disabled 1 : Enabled	0
FB21	: Pipe Fill Frequency Additional frequency to FA09 for filling	0 ~ FA12	5,00 Hz
FB22	: Prefill time Time needed to attempt the filling	0,0 ~ 300,0 seconds	60,0 sec.
FB28	: Fill timeout Wait time for filling	1 ~ 3000 minutes	10 min

- Configure parameters in [7.- Pump Control Menu: Parameter list: Control regulation](#)
There are no special parameters for this mode.

4.2.- Auxiliary functions

The auxiliary functions can be combined with almost all types of pumping regulation described in this manual.

4.2.a.- Water flow detection

This function, if it is enabled, supervises the excessive stability of the system over time, and if **PV** is stable during the time **FA79**, a fictitious **SP** (**SP+FA80**) is automatically generated during the time **FA81**, after which the modified **SP** returns to the previous **SP**. If the demand of the installation consumes that overpressure, it is that the pumping is active and there is a water flow.

On the contrary, if the overpressure persists until making the frequency of the pump lowered to **FA09**, it will fall asleep after the **FA10** waiting time.

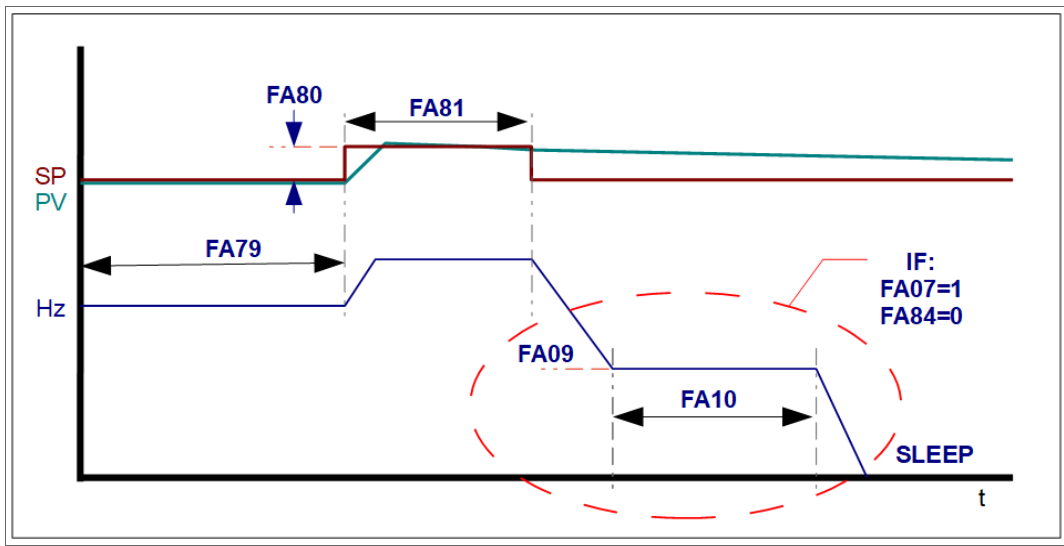

Flow control operation diagram.

- The particular parameters for this mode are indicated below:

Param.	Display / Use	Options/Range	Def.
FA78	: Flow detection Water flow monitoring	0 : Disabled 1 : Enabled	0
FA79	: Flow scan time Interval for flow scan	1 ~ 60000 minutes	60 min.
FA80	: Pressure compensation Pressure to compensate (s/unit in FA34)	0,1 ~ 10,0	2,00
FA81	: NoFlow restart delay Delay of the restart without flow	0,0 ~ 3000,0 seconds	10 sec.

4.2.b.- Cleaning of the pump

This function can only be used in manual mode, so you must have the corresponding "Manual" input activated. The way to use the "Manual" input is indicated in paragraph [4.2.c.- MANUAL / AUTOMATIC control](#) of this manual.

When the input is activated, the pump operates in the forward direction during the time **FB31**, it stops for the time **FB32**, it runs in the opposite direction during the time **FB31**, it do again the pause **FB32**, and so on indefinitely while the input is activated.

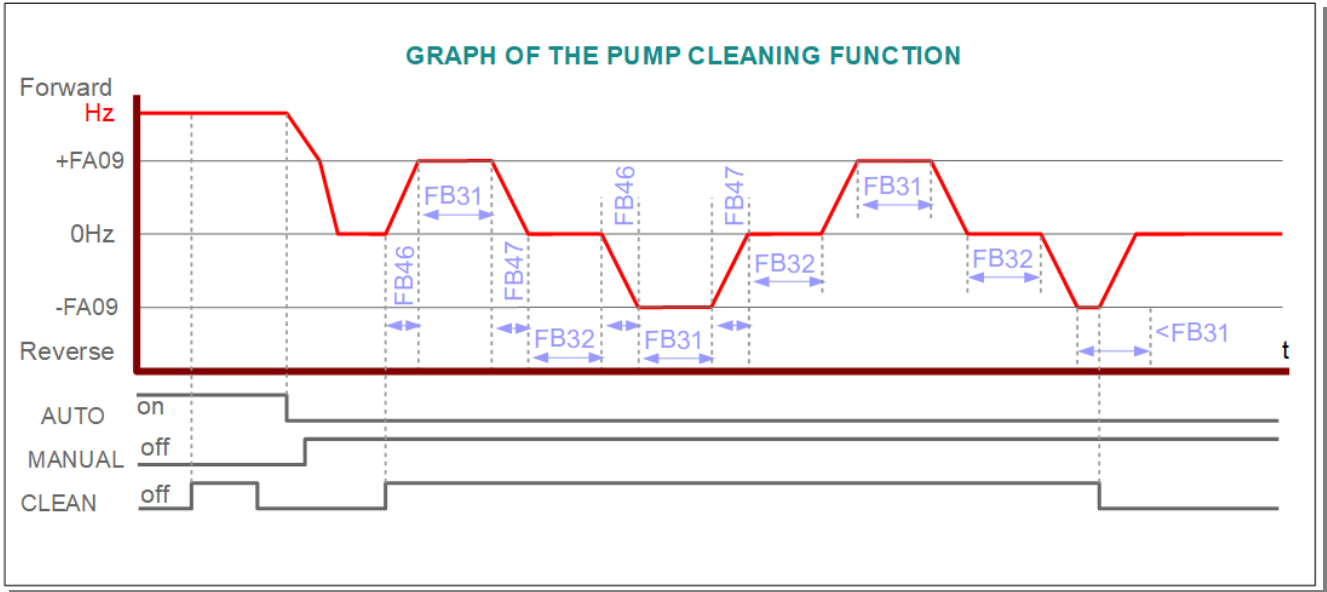

Operating diagram of the pump cleaning function.

To avoid overpressure in the circuit, in case of operating with pressure control, the speed of the pump will not exceed the frequency set in **FA09** (frequency of "falling asleep"). Acceleration and deceleration ramps below this frequency are regulated by **FB46** and **FB47**.

Param.	Display / Use	Options/Range	Def.
F316 ~ F321 (F323)	: Dlx fun. assignment Configure Dlx for the desired state	75 : Cleaning the pump	

Param.	Display / Use	Options/Range	Def.
FB31	: Run time cleaning Operation time	1 ~ 3000 seconds	30 sec.
FB32	: PAUSE Time cleaning Pause time	1 ~ 3000 seconds	30 sec.

The auxiliary parameters for this mode that are set in [7.- Pump Control Menu: Parameter list: Control regulation](#) are indicated below:

Param.	Display / Use	Options/Range	Def.
FB46	: Accel.To freq.Depart. Acceleration time from 0Hz to the starting frequency	0,0 ~ 100,0 seconds NOTE: 0,0 = deactivated	0,0 sec.
FB47	: Decel. Freq.Depart. Deceleration time from starting frequency to 0Hz	0,0 ~ 100,0 seconds NOTE: 0,0 = deactivated	0,0 sec.











4.2.c.- MANUAL / AUTOMATIC control

It may be necessary to manually use the pump or groups of pumps of the installation. The selection of the control method is carried out by an external switch that acts on the **DIx** inputs that have been defined for it.

Assign functions to digital inputs:

Param.	Display / Use	Options/Range	Def.
F316 ~ F321 (F323)	 : Dlx fun. assignment Configure DIx for the desired state	61 : Start/Stop by external input 46 : MANUAL Operation mode Operate with manual SP 47 : AUTO operation mode Operate with automatic SP	

Configure the parameters for when the manual control over the pump(s) is selected: :

Param.	Display / Use	Options/Range	Def.
FB29	 : Activate MANUAL/AUTO Manual/Auto function control	0 : Disabled 1 : Enabled	0
FB10	 : Press. setpoint man. Desired SP for when the manual control is selected	FB13 ~ FB15  NOTE: Bar is the default unit; it can be changed in FA34 .	5,00 Bar
FB11	 : Sleep freq. man. Sleep frequency for when the manual control is selected	F112 ~ F111	5,00 Hz
FB12	 : Sleep delay man. Delay in sleep for when the manual control is selected	0,0 ~ 500,0 seconds	15,0 sec.
FB13	 : Restart press. man. Frequency to wake up when manual control is selected	0,0 ~ FB10  NOTE: Bar is the default unit; it can be changed in FA34 .	0,00 Bar
FB14	 : Restart delay man. Delay in awakening for when the manual control is selected	0,0 ~ 3000,0 seconds	3,0 sec.
FB15	 : Pressur up-limit man. Up-limit pressure for operating alarm with manual control	FB10 ~ FA50  NOTE: Bar is the default unit; it can be changed in FA34 .	10,00 Bar

	NOTE!! There must be an input signal, either MANUAL or AUTO for starting the system when the START input is activated.
---	--

In *simple pump* mode or *pump regulated with fixed pumps* mode operating, the installation does not have any special complexity. The pumps are stopped if S1 is switched off or S2 is set to 0, and it operates with *AUTO* or *MANUAL* pressure as ordered with S2.

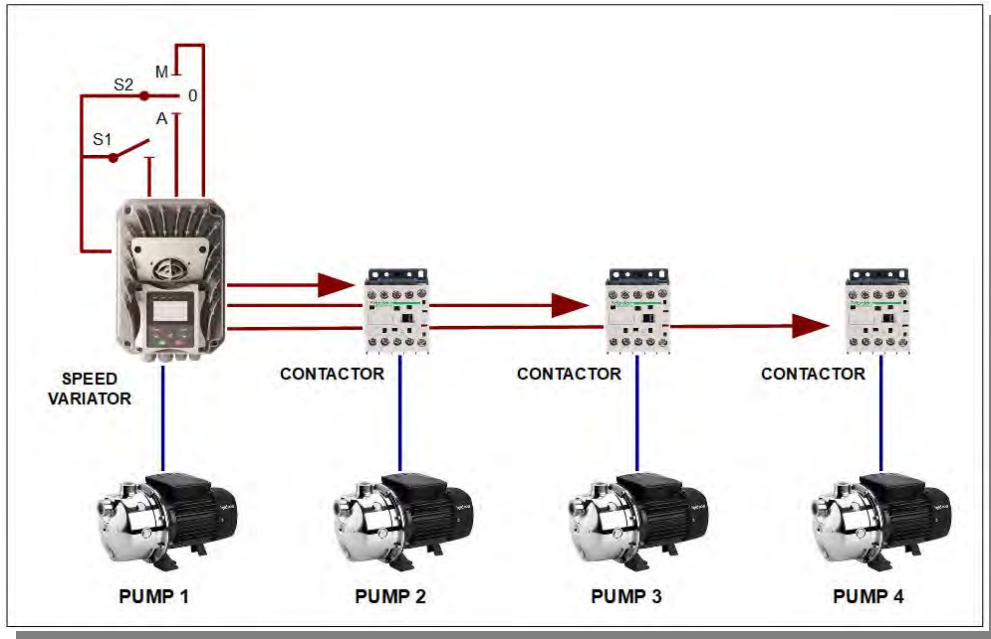

Example of wiring for four pumps, in regulated + fixed mode and *MANUAL/AUTO* function

S1 = Cut-off switch for *START/STOP* signal / S2 = Switch with neutral point for *MANUAL-0-AUTO*

In the *all regulated* mode, with or without alternating *Master*, it is the responsibility of the installer to make the correct wiring so that when the alternation is made, the next logic pump that must enter has the run signal and is in *AUTO*.

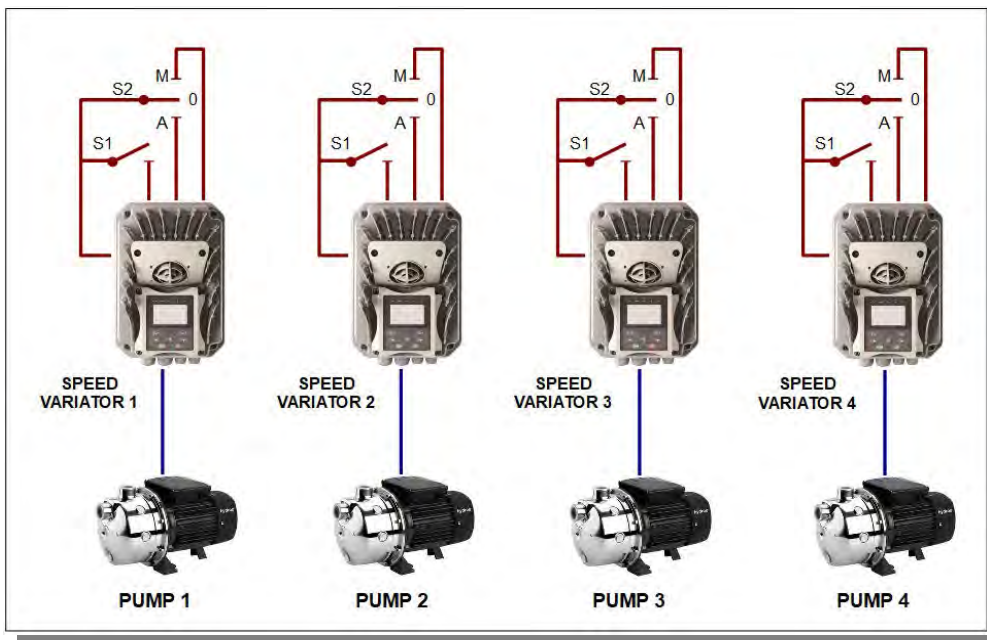

Example of wiring for four pumps in a multimaster group with alternation and *MANUAL/AUTO* function

S1 = Cut-off switch for *START/STOP* signal / S2 = Switch with neutral point for *MANUAL-0-AUTO*

S1 activates the pump in the pressure group, but if S2 is in position 0, it will not start.

The pumps that have S2 in *AUTO* will enter in the *PID* regulation to maintain the pressure in the installation, they will be part of the support pumps, if the *Master* can not maintain *PV* in the *SP* command, and will also become a *Master* when the alternation happens (because of operation of the *Master* or by falling asleep, depending on how it has been parameterized).

Pumps with S2 in *MANUAL* will not be part of the automatic regulation pressure group, and can be started and stopped manually by activating or deactivating S1. It is also always possible to leave S1 activated and start the pump and stop it by manually activating and deactivating S2 in the *MANUAL* position.

4.2.d.- Anti-rust/Anti-freeze

Occasionally, due to the environment of the installation or the working conditions to which the pump is subjected, it must be possible to have the opportunity to periodically make small starts to keep the pump in working condition after very long stops, which could end up blocking the pump shaft due to rust or ice.

If this function is activated, this maintenance function is allowed.

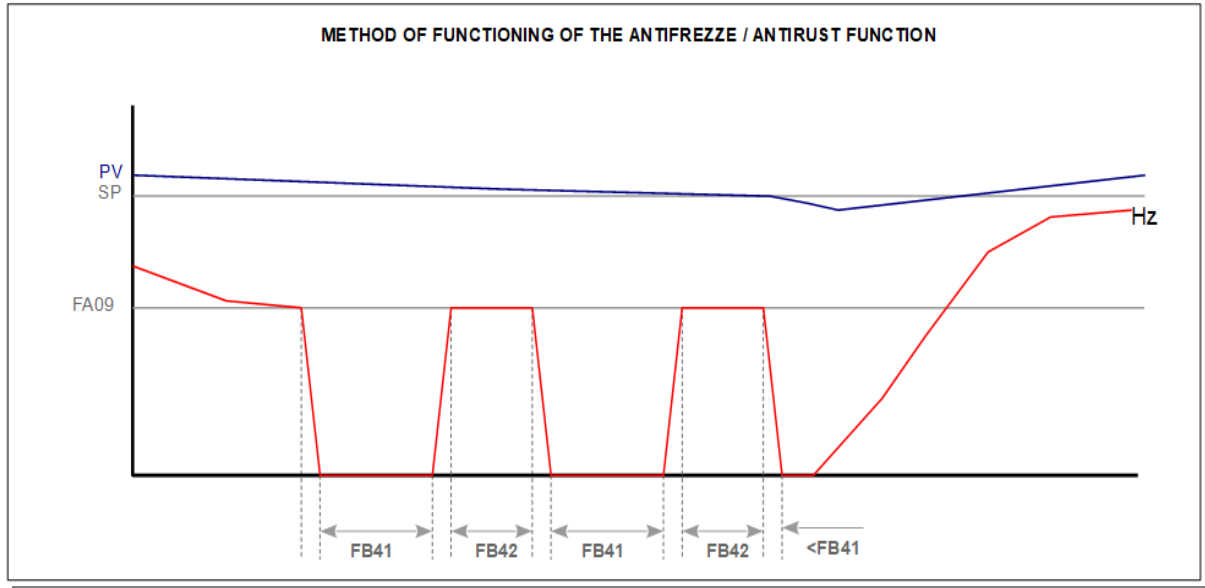







Diagram of operation of the Anti-rust / Anti-freeze control



The special parameters are indicated below.

<i>Param.</i>	<i>Display / Use</i>	<i>Options/Range</i>	<i>Def.</i>
FB40	: Antifreeze/Antisludge Enable Antirust / Anti-freeze	0 : Disabled 1 : Enabled	0
FB41	: STOPtimeAntifr/sludge Pause time	1,0 ~ 3000,0 seconds	60,0 sec.
FB42	: RUNtimeAntifr/sludge Activation time	1,0 ~ 3000,0 seconds	60,0 sec.

4.2.e.- Timer

For irrigation systems, it is important to be able to program the turning on and off of the irrigation system according to hourly needs of the day or daily needs of the week or, in a special way, for having a certain pressure between two time slots and other pressures outside of them.

<i>Param.</i>	<i>Display / Use</i>	<i>Options/Range</i>	<i>Def.</i>
FD00	 : year Parameterization of the clock : Year	2018 ~ 9999	--
FD01	 : month Parameterization of the clock : Month	1 ~ 12	--
FD02	 : day Parameterization of the clock : Day	1 ~ 31	--
FD03	 : Day of the week Parameterization of the clock : Weekday	1 ~ 7	--
FD04	 : hours Parameterization of the clock : Hour	0 ~ 23	--
FD05	 : minutes Parameterization of the clock : Minute	0 ~ 59	--
FD06	 : seconds Parameterization of the clock : Second	0 ~ 59	--
FD07	 : Multi day program Multi-day program	0 : Disabled 1 : Enabled	0
FD08	 : Weekend program Weekend program	0 : Disabled 1 : Enabled	0
FD09	 : Daily program Daily program	0 : Disabled 1 : Enabled	0
FD10 ~ FD31	 : START Day x Star day x (month. day) FD13, FD16, FD19, FD22, FD25, FD28, FD31	01.01 ~ 12.31	01.01
FD11 ~ FD32	 : STOP Day x End day x (month. day) FD14, FD17, FD20, FD23, FD26, FD29, FD32	01.01 ~ 12.31	01.01
FD12 ~ FD33	 : Pressure Day x Day x pressure (%) FD15, FD18, FD21, FD24, FD27, FD30, FD33	FA05 ~ FA03	0
FD34 ~ FD48	 : START x Weekend Start weekend x	00.00 ~ 23.59	0.00
FD35 ~ FD49	 : STOP x Weekend End of the weekend x	00.00 ~ 23.59	0.00
FD36 ~ FD50	 : Pressure x Weekend Weekend pressure x (%)	FA05 ~ FA03	0.0
FD58 ~ FD97	 : START x Day program Daily start x	00.00 ~ 23.59	0.00

<i>Param.</i>	<i>Display / Use</i>	<i>Options/Range</i>	<i>Def.</i>
FD59 ~ FD98	 : STOP 1 Day program Daily end x	00.00 ~ 23.59	0.00
FD60 ~ FD99	 : Press. 1 Day program Daily pressure x x (%)	FA05 ~ FA03	0.0

Summary:

«DAY» PROGRAM				«WEEKEND» PROGRAM				«DAILY» PROGRAM			
N° Prg.	Start	Stop	Pressure	N° Prg.	Start	Stop	Pressure	N° Prg.	Start	Stop	Pressure
1	FD10	FD11	FD12	1	FD34	FD35	FD36	1	FD58	FD59	FD60
2	FD13	FD14	FD15	2	FD37	FD38	FD39	2	FD61	FD62	FD63
3	FD16	FD17	FD18	3	FD40	FD41	FD42	3	FD64	FD65	FD66
4	FD19	FD20	FD21	4	FD43	FD44	FD45	4	FD67	FD68	FD69
5	FD22	FD23	FD24	5	FD46	FD47	FD48	5	FD70	FD71	FD72
6	FD25	FD26	FD27	6	FD49	FD50	FD51	6	FD73	FD74	FD75
7	FD28	FD29	FD30	7	FD52	FD53	FD54	7	FD76	FD77	FD78
8	FD31	FD32	FD33	8	FD55	FD56	FD57	8	FD79	FD80	FD81





NOTE!! Consult the **BLU Service-Center** to know which models and versions of drives have the **RTC** in order to use the timer.

4.2.f.- Solar/well pump autotuning

This function allows to detect, automatically, the exact frequency in which the pump does not pump the water, and therefore the frequency in which the anti-return valve acts.

This is very important for the correct use of the resources of the pumping system, without wasting energy and inadequate heating in the pump.

The frequency where the over-effort of the pump is detected is stored in the minimum working frequency variable, to make the pump falls asleep (FA09).



<i>Param.</i>	<i>Display / Use</i>	<i>Options/Range</i>	<i>Def.</i>
FB00	 : Pump autotuning Activation of the system to perform self-calibration (autotuning) of the pump.	0 : Disabled 1 : Enabled	0
FB01	 : Pump autotuning step Time of permanence in the step of the self-calibration of the pump.	0,1 ~ 5,0 seconds	1,0 sec.
FB02	 : Pump autotuning curr. Current increase for the autotuning step.	0,1 ~ F803	0,1 A

4.2.g.- Anti-return valve control

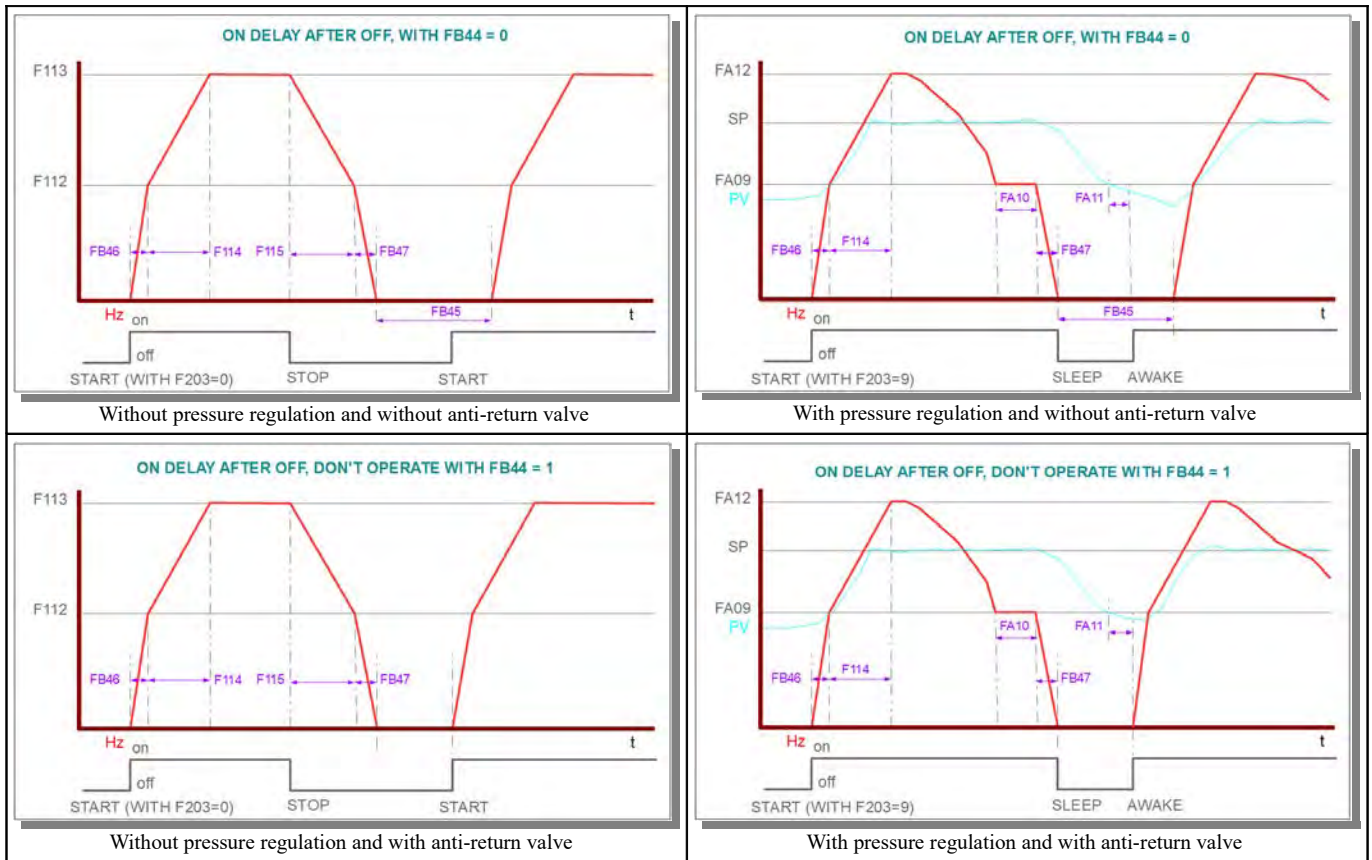
This control affects the pumping operation, when the chosen mode is for well pumps or solar well pumps. If a non-return valve is not installed, it is necessary to wait until the end of the discharge of the water column in the outlet pipe before restarting the pump after stopping it. This is because the pump falls asleep in the extraction mode with pressure control, or has stopped in the manual control mode.



The parameters that control this function are the following:

Param.	Display / Use	Options/Range	Def.
FB44	 : Valve Installed Indicate if a anti-return valve is installed at the outlet of your well/solar well pump	0 : Disabled 1 : Enabled	0
FB45	 : ON delay after OFF Time to wait before a new start/wake order after a stop/sleep	0 : Disabled 1 ~ 99 Enabled (minutes)	3 min.

4.2.h.- Flow meter

In irrigation systems, it is often necessary to count the water flow used in each irrigation area. Therefore, a simple solution to this need is offered.

A digital input to count the pulses of the flow meter and a digital input to reset the counter are available. It also offers the option to predetermine a digital output for an external activation or deactivation when reaching a value, or between a previous value and a final value.

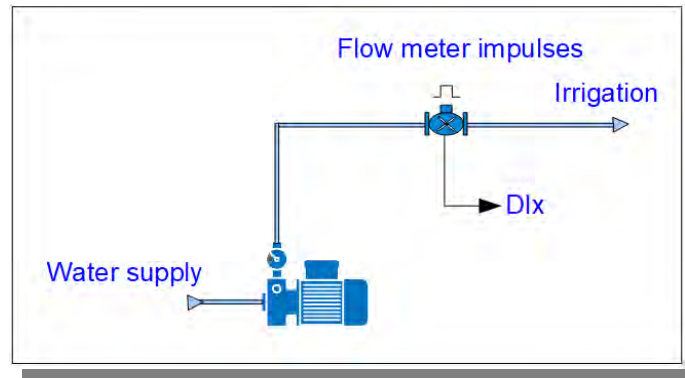

Assign functions to digital inputs in [5.- Pump Control Menu: Parameter list: I / O Configuration](#)



Param.	Display / Use	Options/Range	Def.
F316 ~ F321 (F323)	: Dlx fun. assignment Configure <i>Dlx</i> for the desired states	22: Counter entry 23: Counter reset	
F300	: Rel. func. assignment Configuration of the <i>ROI</i> output relay	8 : Counter value An impulse is generated in the output when reaching the final value of the counter. 9 : Intermediate counter in the defined range The output is activated when the value is reached intermediate and it is deactivated in the final value of counter.	1
F301	: DO1 func. assignment Configuration of the output transistor <i>DO1</i>		14
F302	: DO2 func. assignment Configuration of output relay/transistor <i>RO2/DO2</i>		5

Configure parameters in [7.- Pump Control Menu: Parameter list: Control regulation](#) to be able to visualize the value of the counter while the inverter is running and stopped.

Param.	Display / Use	Options/Range	Def.
F131	: Displayvalve-START Display: Selection of the operating parameters to be displayed on the <u>second line</u> of the auxiliary screen during the " <i>ON</i> " status (motor-running)	Add 64: Counter to the value that appears in this parameter.	15
F132	: Displayvalve-STOP Display: Selection of the operating parameters to be displayed on the <u>second line</u> of the auxiliary screen during the " <i>STOP</i> " state (motor stopped)	Add 32: Counter to the value that appears in this parameter.	6

	The counter is displayed on the auxiliary display screen. To access, press the [FUN] key. When the inverter is stopped, the [←←] key can be used to toggle the display of the values indicated in function F132 . When the inverter is running, the [←←] key can be used to toggle the display of the values indicated in function F131 .
--	---

Configure the particular parameters for this function.



<i>Param.</i>	<i>Display / Use</i>	<i>Options/Range</i>	<i>Def.</i>
F313	 : Counter input divider Divider for impulse input	1 ~ 65000	1
F314	 : Counter final value Final value of the counter	F315 ~ 65000	1000
F315	 : Count. Interm. val. Intermediate value of the counter	1 ~ F315	500

4.2.i.- User macros

Sometimes different configurations must be used for the same pump, for example because it is used in different facilities, under different working and installation conditions.

For this reason, **BLU** allows you to store up to two particular configurations in user memories.

Using the two parameters indicated in the following table, It is possible to store the active parameters in any of the user memories, or recover one of those memories to overwrite the active parameters.

<i>Param.</i>	<i>Display / Use</i>	<i>Options/Range</i>	<i>Def.</i>
F135	 : User default SAVE User macros	0 : Disabled 1 : User macros 1 2 : User macros 2	
F160	 : Default RESET Recovery of values	0 : Disabled 1 : Recover the factory setting 21 : Recover user macros 1 22 : Recover user macros 2	

4.3.- Control modes

There are several control methods defined in the pumping system, which are not present in the menu structure, mainly because they can be used for practically all regulation modes.

4.3.a.- SP Adjustable by impulses of DI inputs

When the pumping system is managed by an external **PLC**, it is possible to modify the **SP** setting by pulses recorded in two digital inputs.

Simply configure an input whose **PULSE** will increase the **SP** and configure an input whose **PULSE** will decrease the **SP**.

Param.	Display / Use	Options/Range	Def.
F316 ~ F321 (F323)	 : Dlx fun. assignment Configure Dlx for the desired states	78 : Increase SP value 72 : Decrease SP value See note (a) of this paragraph	See paragraph 5

	NOTE (a) : The increase and decrease will always be: <u>0,1 units</u> in the values defined by FA34 <u>that have a decimal</u> , <u>1 unit</u> in the values defined by FA34 <u>that are integers</u> .
---	--

4.3.b.- Multiple SP

Sometimes you may have the need to have several **SP**, for example to determine different irrigation pressures depending on the area to be irrigated.

There are three additional **SP**, which with the main **SP**, makes it possible to have 4 different **SP**, to use them conveniently and select them through external inputs.



The function assignment values to the digital inputs are the following:

Param.	Display / Use	Options/Range	Def.
F316 ~ F321 (F323)	 : Dlx fun. assignment Configure Dlx for the desired states	44: SP1 Bit 1 selection for remote setpoint 45: SP2 Bit 2 selection for remote setpoint (see table below)	

SP1	SP2	Active SP	Parameter
--	--	The main SP is active (SP 1)	FA04
ON	--	The auxiliary SP 1 is active (SP 2)	FA86
--	ON	The auxiliary SP 2 is active (SP 3)	FA87
ON	ON	The auxiliary SP 3 is active (SP 4)	FA88

4.4.- Dead band compensation

The following parameter is used to compensate for measurement differences (excessively remote sensor, contrasted measurement differences, etc ...)

Param.	Display / Use	Options/Range	Def.
FA45	 : Deadband comp. Dead band compensation	 The range and number of decimals varies according to the unit of measure selected in FA34.	

4.5.- Avoid "water hammer"









It is essential to avoid water hammer in the installation. With an inverter these should not occur since all actions are activated and deactivated with acceleration and deceleration ramps.













However, it is also possible to set that it is desired to stop the pump by inertia or by ramp. The parameter responsible for this control is indicated below, and is found in the menu [6.- Pump Control Menu: Parameter List: PID Configuration](#)



<i>Param.</i>	<i>Display / Use</i>	<i>Options/Range</i>	<i>Def.</i>
FA33	 : M/S STOP mode <i>STOP</i> mode in the <i>Master/Slave</i> function	0: By inertia The inverter stops controlling the pump, it stops due to its own inertia 1 : By ramp The inverter controls the pump, and stops it with the time ramp defined in F115	

5.- Pump Control Menu: Parameter list: I / O Configuration

The parameters in **CYAN** have the extended information of their use in the corresponding inverter technical manual. The parameters in **ITALIC** can not be changed with the inverter running.

<i>Param.</i>	<i>Display / Use</i>	<i>Options/Range</i>	<i>Def.</i>
F300	 : Rel. func. assignment Configuration of the RO1 output relay	0: No function 1: Variable error 2: Frequency limit 1 3: Frequency limit 2 4: Disabled inverter 5: Inverter START-1 6: DC brake 7: Ramp selection 2 8: Counter value 9: Intermediate counter in the defined range	1
F301	 : DO1 func. assignment Configuration of the output transistor DO1	10: Overloaded inverter 11: Overloaded motor 12: Ramp temporarily stopped 13: Inverter OK 14: Inverter START - 2 15: Setpoint frequency reached 16: Overtemperature alarm 17: Current limit 18: Interruption of the analog signal 19: Lack of water 20: Pre-warning of lack of water	14
F302	 : DO2 func. assignment Configuration of output relay/transistor RO2/DO2	21: Control Modbus 2005H 22: Modbus Control 2006H 23: Modbus Control 2007H 24-29: Reserved 30: RUN Secondary Pump 31: RUN Main Pump 32: Pressure alarm 42: Reserved 43: MODBUS Timeout 2	5
F316	 : DI1 func. assignment Function assignment for DI1 From factory 11 (JOG-forward)	0: No function 1: START function 2: STOP function	11
F317	 : DI2 func. assignment Function assignment for DI2 From factory 9 (EMERGENCY-STDI EXT.)	3: Fixed Frequency K1 4: Fixed Frequency K2 5: Fixed Frequency K3 6: Fixed Frequency K4	9
F318	 : DI3 func. assignment Function assignment for DI3 From factory 15 (TERMINAL "FWD")	7: RESET 8: STOP-Disabled 9: STOP EMERGENCY 10: RAMPSTOP	15
F319	 : DI4 func. assignment Function assignment for DI4 From factory 16 (TERMINAL "REV")	11: JOG Direct 12: JOG Inirect 13: Motorpotentiometer + 14: Motorpotentiometer -	16
F320	 : DI5 func. assignment Function assignment for DI5 From factory (RESET)	15: Terminal "FWD" 16: Terminal "REV" 17: Terminal "X" 18: BIT1 Selection of ramp settings	7





Param.	Display / Use	Options/Range	Def.
F321	 : DI6 func. assignment Asignación de función para DI6 From factory (STOP-DISABLE)	19: Reserved 20: M / n (Speed/Pair) 21: Setpoint supply 22: Counter entry 23: Counter reset 24-29: Reserved 30: Lack of water 31: Water OK 32: Pressure FIRE 33: FIRE MODE	8
F322	 : DI7 func. assignment Asignación de función para DI7 From factory (START)  Solo en EP66 y E2000 >22kW	34: Selection of Ramp settings BIT2 35: Parameter Setting (BIT1) 36: Parameter Setting (BIT2) 37: NTC / NO 38: PTC / NC 49: PID-STOP 48: Internal PID	1
F323	 : DI8 func. assignment Asignación de función para DI8 From factory (STOP)  Solo en EP66 y E2000 >22kW	51: Alternative motor 53: Watchdog 60: RS485 Timeout reset 61: START / STOP 71: Make filling 72: Emptying 73: HIGH level entry 74: LOW level entry 75: Carry out pump cleaning 78: Increase setpoint (+1 or +0.1 according to unit) 79: Decrease setpoint (-1 or -0.1 according to unit)	2
F340	 : DIx logic inversion To invert the digital input logic	0: Disabled 1: DI1 inverted 2: DI2 inverted 4: DI3 inverted 8: DI4 inverted 16: DI5 inverted 32: DI6 inverted 64: DI7 inverted 128: DI8 inverted  Example: Inverter DI2 y DI3 = 1+4 =5	0
F400	 : AI1 Lower limit Low range limit (V) for AI1	0.00V... F402  If the sensor is 4...20mA, F400 =2.00 and observe the positioning of the switches on the control board.	0,04V
F406	 : AI2 Lower limit Low range limit (V) for AI2	0.00V... F408  If the sensor is...20mA, F406 =2.00 and observe the positioning of the switches on the control board.	0,04V
F431	 : AO1 function assign Assignment of operational parameters in AO1	0: Motor Frequency 1: Motor Current (For 2xI-n) 2: Motor Voltage (For 230/400V)	0
F432	 : AO2 function assign Assignment of operational parameters in AO2	3: AI1 4: AI2 5: Input Pulses 6: Par- for Nm 7: Via MODBUS 8: Target frequency 9: Calculated speed 10: Par (motoric)	1

<i>Param.</i>	<i>Display / Use</i>	<i>Options/Range</i>	<i>Def.</i>
F438	 : AI1 U/I selection Type of entry for AI1	0: Voltage mode 1: Current mode	0
F439	 : AI2 U/I selection Type of entry for AI2	0: Voltage mode 1: Current mode	1

	<p>About F300, F301 and F302</p> <p>Hardware outputs in EM30 : 1 = Relay RO1, 2 = Transistor DO1, 3 = Relay RO2 (all sizes)</p> <p>Hardware outputs on EP66 : 1 = Relay RO1, 2 = Transistor DO1 (<15kW)</p> <p>Hardware outputs on EP66 : 1 = Relay RO1, 2 = Transistor DO1, 3 = Transistor DO2 (18.5 ~ 90kW)</p> <p>Hardware outputs in E2000 : 1 = Relay RO1, 2 = Transistor DO1 (<30kW)</p> <p>Hardware outputs in E2000 : 1 = Relay RO1, 2 = Transistor DO1, 3 = Transistor DO2 (30 ~ 400kW)</p>
---	--

6.- Pump Control Menu: Parameter List: PID Configuration



The parameters in **CYAN** have the extended information of their use in the corresponding inverter technical manual. The parameters in **ITALIC** can not be changed with the inverter running.

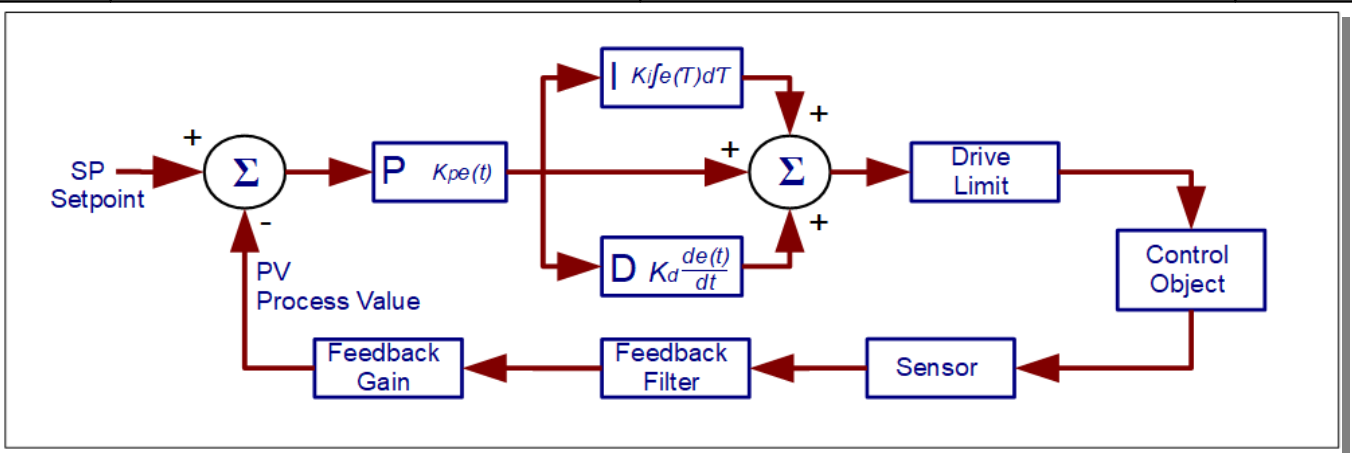















Param.	Display / Use	Options/Range	Def.
FA00	 : PID Controller mode Controller settings	0: Simple pumping control 1: Regulated + fixed mode (WITHOUT <i>Slave</i> rotation) 6: Regulated + fixed mode (rotation of <i>Slaves</i> by running time) 7: Regulated + fixed mode (rotation of <i>Slaves</i> when the <i>Master</i> falls asleep) 10: Multimaster fixed pumps 11: Multimaster <i>Master</i> rotation by time 12: Multimaster <i>Master</i> rotation at sleep	0
FA01	 : PID setpoint channel <i>PID</i> set point	0: Internal reference (value in FA04) 1: <i>AI1</i> analog input 2: <i>AI2</i> analog input 3: <i>AI3</i> (keypad potentiometer) 4: Frequency (pulse input)	0
FA02	 : PID deed-back channel <i>PID</i> feedback	1: <i>AI1</i> analog input 2: <i>AI2</i> analog input 3: Frequency (pulse input) 4: Reserved 5: Motor current 6: Output power 7: Par output	1
FA34	 : Measurement unit Pressure unit/measure unit	0 : % 1 : Mpa 2 : Bar 3 : psi 4 : cm 5 : M 6 : cm/Sec 7 : M/Sec 8 : °C	2



















Graphic representation of the *PID* action.

To activate the *PID* action, set **F203** = 9 to 7.- Pump Control Menu: Parameter list: Control regulation

FA05	 : Contr. Range low. lim Lower control limit (unit of <i>SP</i>)	0.0... FA04	0,0 Bar
FA04	 : Internal PID setpoint Internal set point value (<i>SP</i>)	FA05 ... FA03	50
FA03	 : Contr. range upp.lim Upper control limit Set <i>NP</i> alarm threshold	FA04 ... FA50 See note (1) at the bottom of this table	100,0 Bar













Param.	Display / Use	Options/Range	Def.
FA50	 : Main Pressure Range Pressure range of the <u>transmitter of the pressure group</u> See note (b)	FA03....100,0 bar See note (a)	100,0 Bar
FA06	 : PID polarity POS/NEG PID control polarity	0 : Positive 1 : Negative	1
FA19	 : PID proportional gain Proportional Gain <i>P</i>	0,00...10,00	0.3
FA20	 : PID Integration time Integral Time <i>I</i>	0,1...100,0 seconds	0.3 sec.
FA21	 : PID Differential time Differential Time <i>D</i> (sec.)	0,00...10,00	0,0 sec
FA22	 : PID Sampling rate Time cycle control / scan coefficient (sec.)	0,1...10,0 seconds	0,1 sec.
FA29	 : PID Dead zone Dead band adjustment (% of the set point)	0,0 – 10,0 %	2,0 %
FA45	 : Deadband comp. Dead band compensation	See note (a)	0,0 Bar
FA12	 : PID Max. frequency Maximum working frequency in <i>PID</i>	FA09.....F111 (Hz)	50 Hz
FA07	 : Sleep mode enable Automatic sleep mode	0: activated 1: disabled	1
FA84	 : PID sleep mode PID sleep mode	0 : Sleep in FA09 <i>PV</i> is in FA09 during FA10, it falls asleep. 1 : Sleep below FA09 (F112) <i>PV</i> is in FA09 during half the time of FA10, the frequency of the pump goes down to F112 during the other half of the time of FA10 and it falls asleep.	0
FA09	 : Freq. threshold sleep Frequency threshold to activate the sleep function	F112~F111	5,00 Hz
FA10	 : Delay-time sleep Delay for the Sleep function	0...500 seconds	15 sec.
FA11	 : Delay time wake-up Delay for the reactivation of the function Sleeping (sec.)	0...3000 seconds	3.0 sec.
FA67	 : Wake-up mode Mode in which the pumping system "wakes up"	0 : Restart (wake up) mode 1 If FA06=0, Wake up with the <u>absolute pressure</u> marked on FA05 1 : Restart (wake up) mode 2 If FA06=0, Wake up with the <u>relative pressure</u> of SP+FA68 If FA06=1, Wake up with the <u>relative pressure</u> of SP-FA69	0
FA68	 : Restart press (+) Pressure for restart (wake up) when a positive <i>PID</i> is performed (FA06 = 0)	See note (a)	2.0



Param.	Display / Use	Options/Range	Def.
FA69	 : Restart press (-) Pressure for restart (wake up) when a negative <i>PID</i> is performed (FA06 = 1)	See note (a)	2.0
FA33	 : M/S STOP mode <i>STOP</i> mode in the <i>Master/Slave</i> function	0: By inertia The inverter stops controlling the pump, it stops due to its own inertia 1: By ramp The inverter controls the pump, and stops it with the time ramp defined in F115	
FA55	 : M/S Pump number Pump number in the <i>Master/ Slave</i> chain	0 ~ 14	0
FA56	 : Main sensor fault See note (b)	0 : Deactivated 1 : Error message Aer0	0
FA86	 : Int. PID setpoint 2 Second <i>SP</i> selectable by entry	FA05~FA03	
FA87	 : Int. PID setpoint 3 Third <i>SP</i> selectable by entry	FA05~FA03	
FA88	 : Int. PID setpoint 4 Fourth <i>SP</i> selectable by entry	FA05~FA03	
FA30	 : Inv. Pump startdelay Delay to start an auxiliary pump in case of need	2,0~999,9 seconds	20,0 sec.
FA31	 : Pump startdelay Delay to start a linked pump in case of need	0,1~999,9 seconds	30,0 sec.
FA32	 : Pump stopdelay Delay to stop a linked pump if it is not necessary (sec.)	0,1~999,9 seconds	30,0 sec.
FA44	 : M/S control mode It establishes the behavior of the <i>Slave</i> with respect to the <i>Master</i> being linked	0: <i>Slave</i> Setpoint = <i>Master</i> Setpoint The <i>Slave</i> operates in a twin way to the <i>Master</i> , regulates his speed at the same time 1: <i>Slave</i> Setpoint = <i>PID</i> setpoint The <i>Slave</i> operates independently to the <i>Master</i> , <i>PID</i> regulates your speed	0
FA99	 : Param. synchronizing It allows to synchronize from a <i>Slave</i> the parameters of regulation and control of the <i>Master</i> (See 3.b.3.- Synchronized parameters to know the ones that are synchronized)	0 : Disabled The <i>Slave</i> keeps its own parameters 1 : Activated The <i>Slave</i> copies the parameters of the <i>PID</i> and of the regulation of the <i>Master</i> (* See 3.b.- Automatic synchronization	0

















	NOTE(1) : When the pressure reaches the set value, protection is activated. If the inverter is running, it will stop, indicating the error " nP "
	NOTE (2) : When the pressure reaches the set value, protection is activated. If the inverter is running, it will stop, indicating the error " nP1 "
	NOTE (a) : The range and number of decimals varies according to the unit of measure selected in FA34 .
	NOTE (b) : The definition "INPUT" and "OUTPUT" for the parameters is specified for the sensors corresponding to the positioning position specified in 1.3.- Pressure empty mode . To avoid misunderstandings in the other applications, the output sensor is indicated as the MAIN SENSOR and the input sensor is indicated as the AUXILIARY SENSOR.







7.- Pump Control Menu: Parameter list: Control regulation

The parameters in **CYAN** have the extended information of their use in the corresponding inverter technical manual. The parameters in **ITALIC** can not be changed with the inverter running.

Param.	Display / Use	Options/Range	Def.
F106	 : Control algorithm Adjust the Control algorithm as needed.  For pumps, the most usual is 2:V/Hz	0 : Sensorless Vector (SLV) 1 : Reserved 2 : V/Hz mode 3 : Vector (Slip compensation) 6 : Synchronous motor control	2
F112	 : Minimum frequency Minimum work frequency  (Do not confuse with the sleep frequency of pumps)	0.00 - F113 Hz	0,50 Hz
FB46	 : Accel.To freq.Depart. Acceleration time from 0 Hz to start frequency.	0,0~100,0 seconds	0,0 sec.
F114	 : 1. Acceleration ramp Normal acceleration ramp	0.1 – 3000 seconds	5.0 sec.
FB47	 : Decel. Freq.Depart. Deceleration time from starting frequency to 0Hz.	0,0~100,0 seconds	0,0 sec.
F115	 : 1. Deceleration ramp Normal deceleration ramp (sec.)	0.1 – 3000 sec.	5.0 sec.
F138	 : V/Hz Lin. BOOST Linear/quadratic boost curve	1 - 20	According to VAR
F153	 : Carrier frequency Switching frequency PWM of the transistors	0.2 - 7.5 kW : 800 Hz – 16.000 Hz 11 – 15 kW : 800 Hz – 10.000 Hz 18.5 kW – 45 kW : 800 Hz – 6.000 Hz >55kW : 800 Hz – 4.000 Hz	4kHz 3kHz 4kHz 2kHz
F159	 : Random carrier "RANDOM" PWM modulation	0 : PWM constant frequency 1 : "RANDOM" modulated PWM	1
F131	 : Displayvalue-START Display: Selection of the operating parameters to be displayed on the <u>second line</u> of the auxiliary screen during the "ON" status (motor-running)	0: Output frequency/value of param. 1: motor speed (rpm) 2: Motor current 4: Motor voltage 8: DC voltage 16: PID control feedback 32: Heatsink temperature 64: Counter 128: Speed (linear - calculated) 256: PID setpoint 512: Reserved 1024: Reserved 2048: Motor-Power 4096: Motor-Torque 8192: Reserved	0 +1 +2 +4 +8 =15

<i>Param.</i>	<i>Display / Use</i>	<i>Options/Range</i>	<i>Def.</i>
F132	 : Displayvalue-STOP Display: Selection of the operating parameters to be displayed on the <u>second line</u> of the auxiliary screen during the "STOP" state (motor stopped)	0: Frequency set/Param. (Fxxx) 1: Module Jog by keypad - HF-0 2: Motor speed determined (RPM) 4: DC voltage 8: Feedback of the PID control 16: Heatsink temperature 32: Counter 64: PID setpoint 128: Reserved 256: Reserved 512: Torque control reference 1024: Reserved 2048: Reserved	0 +2 +4 =6
F645	 : Main Display Display: Value to represent in the <u>first line</u> of the auxiliary screen	0: Output frequency 1: RPM 2: RPM setpoint 3: Motor current 4: Motor voltage 5: DC bus voltage 6: PID setpoint (SP) 7: Return PID (PV) 8: Heatsink temperature 9: Counter 10: Calculated speed 11: First frequency reference 12: First frequency 13: Second frequency reference 14: Second frequency 15: Internal setpoint 17: TORQUE 18: TORQUE setpoint 19: Rated power of the inverter 20: Output power 21: State of the inverter 22: DI Monitor terminals 23: DO Monitor terminals 24: Preset speeds 25: A11 Analog value 26: A12 Analog value 29: Input pulse frequency 30: Output pulse frequency 31: AO1 Analog value 32: AO2 Analog value 33: Power on hours 34: Reserved 35: Reserved 36: Irradiation	0
F202	 : Rotation direction It makes possible to invert the direction of rotation of the pump	0 : Direct rotation 1 : Inverse rotation 2: Terminals DI controlled 3: Keypad controlled 4: Keypad + dir. memory	0

Param.	Display / Use	Options/Range	Def.
F203	 : Primary setpoint X Possible reference input ways of the first speed "X"  For all pumping operation with pressure sensor F203=9 : <i>PID</i> control (except "Level control" and regulation by keypad potentiometer)	0 : Internal reference (F113) with memory 1: <i>A11</i> analog input 2: <i>A12</i> analog input 3: Pulsetrain input 4: Fixed frequencies, by terminals (Digital inputs) 5: Same as 0, (F113) but without memory 6: Reserved 7: Reserved 8: Reserved 9: <i>PID</i> control 10: <i>MODBUS</i>	0
F204	 : Secondary setpoint Y Possible reference input ways of the second speed "Y"  It can be combined with F203 , using the selected way in F207	0: Internal reference (F155) with memory 1: <i>A11</i> analog input 2: <i>A12</i> analog input 3: Pulsetrain input 4: Fixed frequencies, by terminals (Digital inputs) 5: <i>PID</i> control 6: Reserved	0
F207	 : Speed setpoint source Output frequency as a combination of the setpoints of the first ("X") and the second ("Y") speed.	0: X, Only the first setpoint is used 1: X + Y Sum of the two slogans 2: X or Y (selection by terminals) 3: X or X + Y (selection by terminals) 4: X (Fixed Frequencies) and Y (Analog) combined 5: X-Y Difference between the two setpoint values 6: X + Y (F206 -50%) * (value defined in F205)	0
F208	 : 2/3 Wire control mode Start/stop by two, three cables	0: Disabled 1: Two cables, type 1 (static) 2: Two cables, type 2 (static) 3: Three wires, type 1 (Pulse / Pushbutton - dynamic) 4: Three cables, type 2 (Pulse / Pushbutton - dynamic) 5: Pulse / Pushbutton - dynamic	0
F213	 : Power-ON Autostart Autostart after a power drop	0: Disabled 1: Activated	0
F215	 : Autostart - delay Autostart delay after power drop	0,1...3000,0 seconds	60,0 sec.
F900	 : Inv. adress assignment Electronic address (unit number) of the inverter	1...15  (In operation, if duplicate device numbers are detected, error E001 is signaled)	1
F160	 : Default RESET Reverting the inverter to manufacturer values	0 : Normal Operation 1 : Factory Parameters See procedure in: <u>II.d1- Return the inverter to its default factory settings</u>	0
F801	 : Motor rated power Rated power on the motor plate (kW)	0.2...1000 kW	
F802	 : Motor rated voltage Rated voltage on the motor plate (V)	1...440 V	
F803	 : Motor rated current Rated current on the motor plate (A)	0.1...6500 A	
F804	 : Pole Nr. (READ-ONLY) Number of poles (p) (only reading !!)	Automatic calculation	
F805	 : Motor rated rpm Rated speed on the motor plate (RPM)	1...30000 U/min	

<i>Param.</i>	<i>Display / Use</i>	<i>Options/Range</i>	<i>Def.</i>
F806	 : Resist..stator.motor Stator resistance (Ohm)	0.001...65.00 Ohm	
F807	 : Resist.rotor.motor Rotor resistance (Ohm)	0.001...65.00 Ohm	
F808	 : Leakage inductance Leakage inductance (mH)	0.01...650.0 mH	
F809	 : Main inductance Main inductance (mH)	0.1...6500 mH	
F810	 : Motor rated frequency Rated motor frequency (Hz)	1.0...300.0 Hz	50,00 Hz
F800	 : AUTOTUNING Mode Measurement of motor data (AUTOTUNING)	0 : AUTOTUNING disabled 1 : START AUTOTUNING dynamic 2 : START AUTOTUNING static See procedure in: II.d2- Motor autotuning	0
FA96	 : Level Control Level control function	0 : Deactivated 1 : Enabled	0

8.- List of alarms

The operation of the pumping system is continuously supervised and in the case of need to report a state, an anomaly, or malfunction, the inverter will do it using the following list of messages:

Display	Definition	Corrective action
:E001	Duplicate device (in F900)	Check the configuration of the chain drives.
2:OC	Overcurrent	Increase the time of Ac./Deac. Check the motor wiring. Check the mechanical system. Reduce the starting torque. Check motor parameters
3:OE	Overvoltage	Check the voltage input. Correct Rated voltage of the inverter. Use braking resistors. Increase the deceleration time.
4:PF1	Lack of entry phase	Check network entry.
5:OL1	Overloaded inverter	Reduce the power Check the dimensioning of the equipment.
6:LU	Low input voltage Voltage on the <i>DC BUS</i> too low	Check network supply
7:OH	Overheating of the inverter	Check environmental working conditions. Check the parameterization Check the drive assembly.
8:OL2	Motor overload	Reduce the load Check the dimensioning of the equipment .
11:ESP	External emergency	Disconnect external emergency condition, emergency button, safety curtain, etc.
12:Err3	Over-current in STOP situation	Visual inspection of the inverter and the installation. Contact BLU Service-Center
13:Err2	Autotuning Error	The motor has not rotated freely during the TEST process, leaving the motor on free axle
15:Err4	Current sensor error, there is no current signal on the control board	Visual inspection of the inverter. Contact BLU Service-Center
16:OC1	Over current software detected	Increase the time of Ac./Deac. Check the motor wiring. Check the mechanical system. Reduce the starting torque. Check motor parameters.
17:PF0	Balance in output phases	Check motor and wiring.
18:AErr	Interruption of the analog signal	Check the wiring. Review the correct programming of the minimum limit. Check the analog input signal.
19:EP3	Inverter with low load or little water	Review of mechanics. Reset the water supply.
20:EP		
20:EP2		
22:nP	Pressure outside limits	Faulty Pump Control Settings. Check water supply.
23:Err5	Error in the PID control	Review incorrect parameterization of the PID
24:SLP	The inverter is "asleep"	As a result of the correction of the PID , the operating frequency has been in FA09 during the FA10 time.
25:EP4	Detected dry operation	Check admission circuit to the pump (s). Check that the inlet valves are open. Check that there is water in the inlet pipe.

Display	Definition	Corrective action
32:PCE	Error in the autotuning of the permanent magnet synchronous motor	The motor has not rotated freely during the TEST process, leaving the motor on free axle
35:OH1	Overheated motor	Check the motor .
45:CE	<i>MODBUS</i> out of time	Check <i>MODBUS</i> wiring. Check <i>MODBUS</i> parameterization
47:EEEP	<i>EEPROM</i> error	Contact BLU Service-Center
49:Err6	Watchdog out of time	Check the <i>Watchdog</i> in the assigned digital input
55:SLP1	The inverter is "asleep" because of <i>INI</i> (input sensor)	As a result of the correction of the <i>PID</i> , the operating frequency has been in FA09 during the FA10 time.
56:nP1	Pressure outside limits in <i>INI</i> (input sensor)	Faulty Pump Control Settings. Check water supply.
57:EP5	Dry operation detected <i>INI</i> (input sensor)	Check admission circuit to the pump (s). Check that the inlet valves are open. Check that there is water in the inlet pipe.
58:AEr0	Sensor signal <i>IN2</i> (output sensor) not detected	Check the wiring. Check the sensor connected to <i>IN2</i> .
67:OC2	Over current software detected	Increase the time of Ac./Deac. Check the motor wiring. Check the mechanical system. Reduce the starting torque. Check motor parameters.
69:EP6	Water leak detected	Check pipes. Check obstruction in the circuit or semi-closed valves.
71:FILL	Failed filling function	Check pipeline installation .
72:ErAT	Error in autotuning well/solar pump	The autotuning has ended without finding the pressure point of the anti-return valve.
73:AEr1	Sensor signal <i>INI</i> (input sensor) not detected	Check the wiring. Check the sensor connected to <i>INI</i> .
74:ErT0	Time control parameters improperly adjusted	Review the parameters of section FDxx .
75:ErJA	Jam detected in the pump	Check that there is no solid body blocking the rotation of the pump.
76:SSLP	The inverter is "asleep" by the action of the solar irradiation sensor (insufficient irradiation)	There is no corrective action, review FB56 , FB55 or FB57 . As a result of the <i>PID</i> correction, the operating frequency has been at FA09 during the FA10 time.

THESE codes and error messages are specific to the pump control, and do not appear in normal operation.



9.- Observations for optimal running

In the following paragraphs some important recommendations are provided for an optimal adjustment of the installation.

9.1.- The process units and PID

The pump control program can be used in multiple applications; sanitary pumping, irrigation pumping, pumping for fire-fighting, etc ...But its functions, with a little imagination and with the appropriate parameterization, can also be used for applications of ventilation, vacuum, heating or cooling circuits hydraulic, etc ...

All depends on how the **PID** control is parameterized.

<i>Param.</i>	<i>Display / Use</i>	<i>Options/Range</i>	<i>Def.</i>
FA00	 : PID Controller mode Controller settings	0: Simple pumping control 1: Regulated + fixed mode (WITHOUT <i>Slave</i> rotation) 6: Regulated + fixed mode (rotation of <i>Slaves</i> by running time) 7: Regulated + fixed mode (rotation of <i>Slaves</i> when the <i>Master</i> falls asleep) 10: Multimaster fixed pumps 11: Multimaster <i>Master</i> rotation by time 12: Multimaster <i>Master</i> rotation at sleep	0
FA06	 : PID polarity POS/NEG Polarity control <i>PID</i>	0 : Positive (also called direct) 1 : Negative (also called indirect)	1

And of the process units that are applied.

<i>Param.</i>	<i>Display / Use</i>	<i>Options/Range</i>	<i>Def.</i>
FA34	 : Measurement unit Pressure unit / unit of measure	0 : % 1 : Mpa 2 : Bar 3 : psi 4 : cm 5 : M 6 : cm/Sec 7 : M/Sec 8 : °C	2

9.2.- Acceleration and deceleration

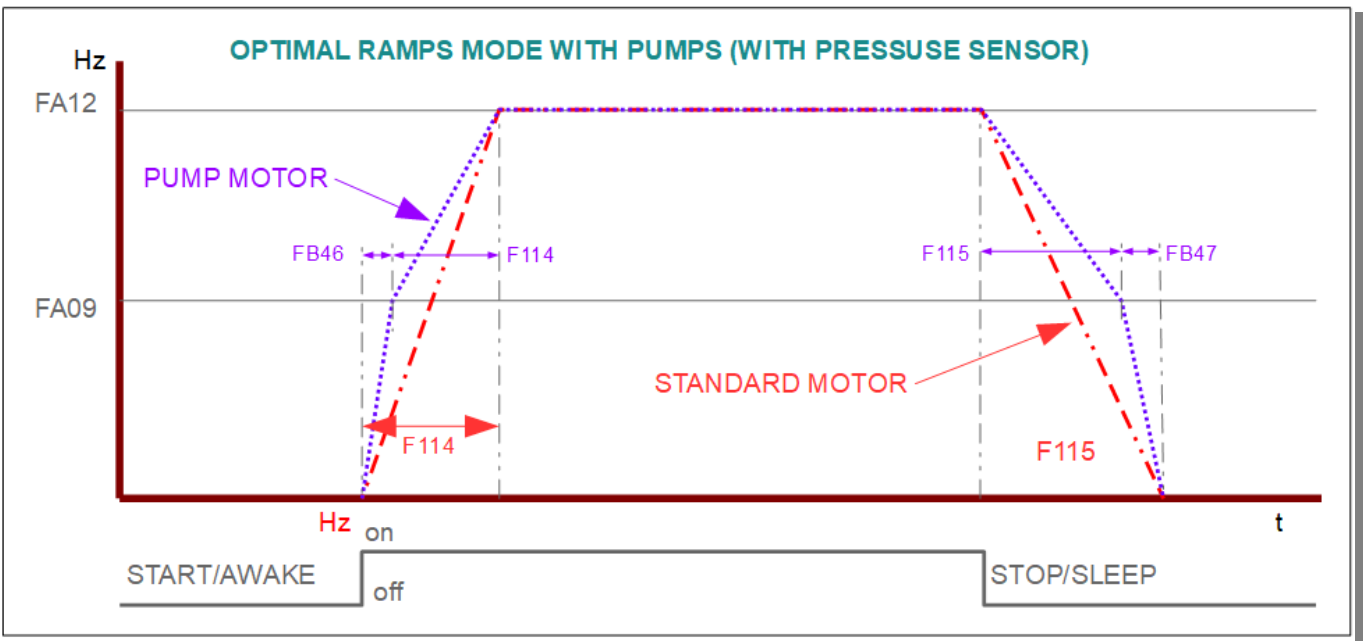
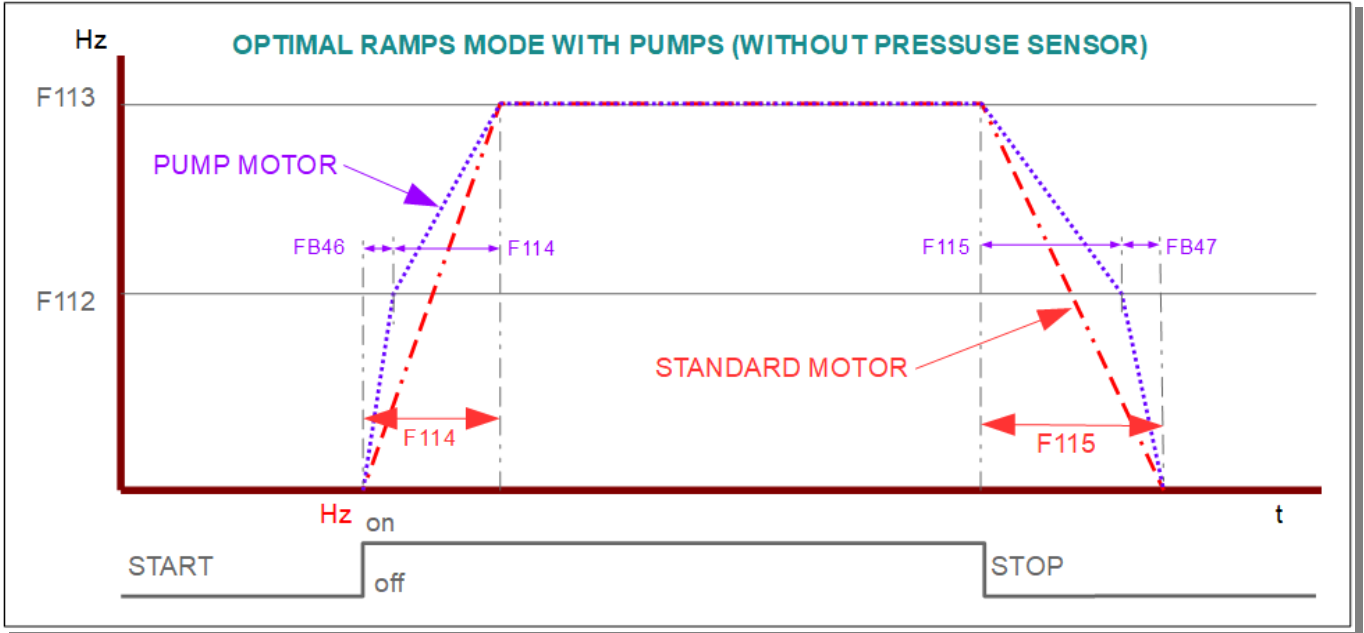

Unlike normal motors, the pumps (especially the wells pumps, regardless of whether their supply is grid or solar) must start the acceleration ramp from the minimum frequency of the pump, set to **F112** if it is not operating with pressure sensor, or from **FA09** if pressure sensor is used, instead of from 0Hz. To protect the pump and the inverter itself with excessively abrupt accelerations, special times are established to reach these frequencies. From these frequencies, standard times are used to reach 100% pump speed.

Below, there is showed some graphs that represent the operation explained in the previous paragraph are shown.





9.3.- Activation of auxiliary pumps (fixed or regulated)

The special parameters to activate a supportive fixed pump to the regulation pump or another regulation pump to the chain of the pressure group are detailed in the following table and graph:

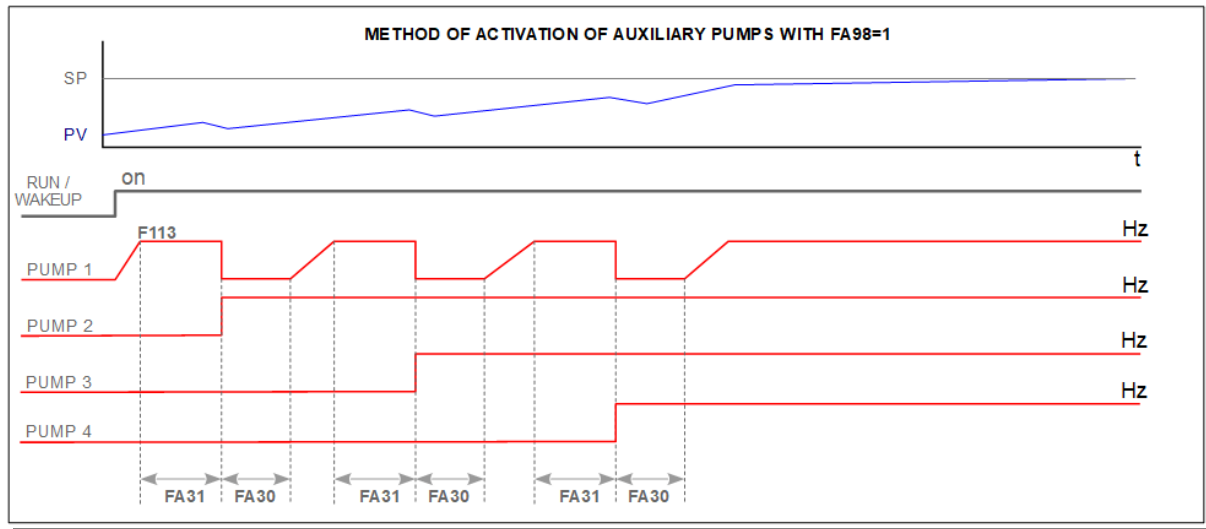
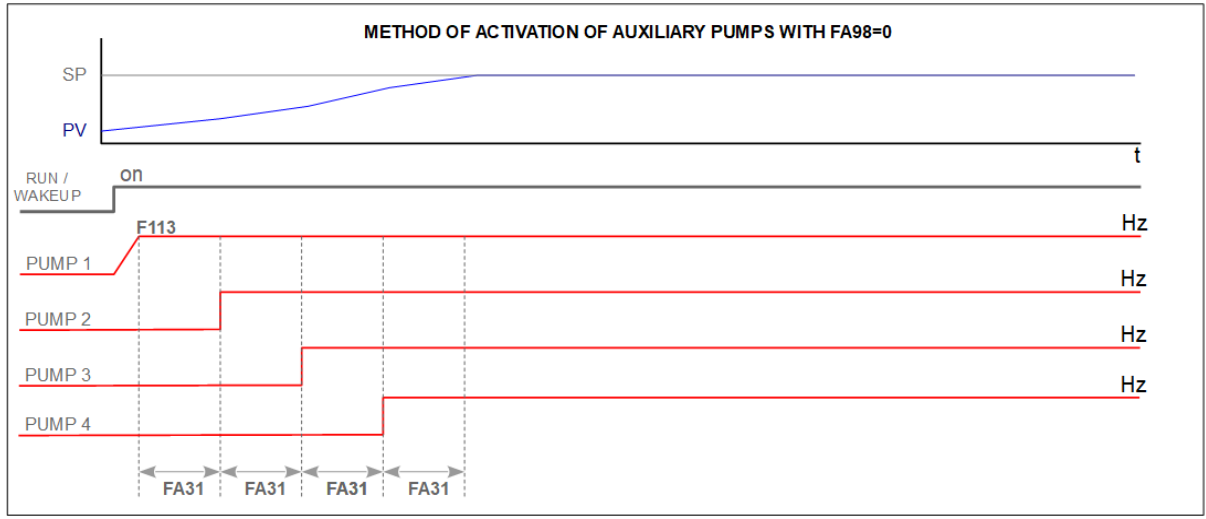
Param.	Display / Use	Options/Range	Def.
FA30	 : Inv. Pump startdelay Delay to start an auxiliary pump in case of need	2,0~999,9 seconds	20,0 sec.
FA31	 : Pump startdelay Delay to start a linked pump in case of need	0,1~999,9 seconds	30,0 sec.
FA98	 : Interchange VFD/POWER Regulated pump stop when a fixed pump start	0 : Disabled 1 : Enabled	1



	The graphic representation indicates the operation with fixed pumps, starting by contactor or starter. If the auxiliary pumps were regulated pumps, that is controlled by an inverter in the pumps chain, the FA31 time would start counting at the end of the acceleration ramp defined by parameter F114 , once the inverter is at the maximum frequency of the pump (F113).
	The operation of only the first four pumps has been represented. In the "All regulated" mode, the maximum number of linked pumps is 15 .

9.4.- Deactivation of fixed auxiliary pumps

The fixed pumps are deactivated from the pump chain in a simple way, controlled by the following time parameter:

Param.	Display / Use	Options/Range	Def.
FA32	 : Pump stopdelay Delay to stop a pump at the frequency of falling asleep (FA09)	0,1 ~ 999,9 seconds	30,0 sec.

Its behavior is described in the chart below.

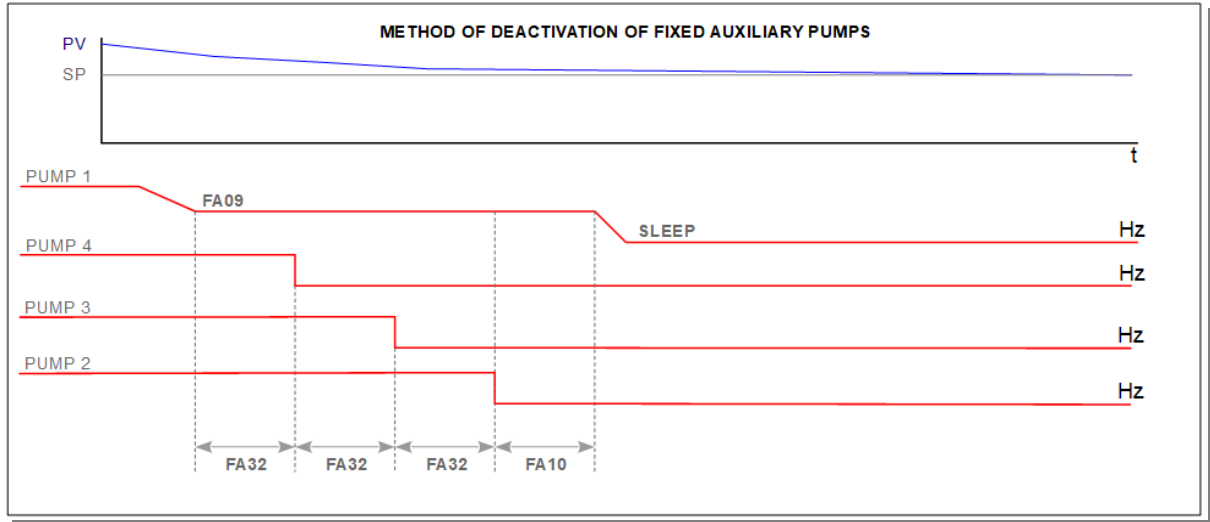

If the *PV* pressure is above the adjusted *SP* the *PID* of the regulated pump will lower its speed to the frequency set for falling **FA09**. From then on the pump will start operating the **FA32** time, which at the end will disconnect the last activated pump, again controlling the **FA32** time to disconnect the antepenultimate. And so on until only the regulated pump is in operation, which will fall asleep after **FA10** time if there is no demand for pressure.

If there is a demand for pressure while the system is in the process of disconnecting pumps, the disconnections will be suspended to reactivate the pump that proceeds.

9.5.- Deactivation of regulated auxiliary pumps

Regulated pumps are deactivated from the chain in two different ways, depending on the setting of the following parameter:

Param.	Display / Use	Options/Range	Def.
FA44	 : M/S control mode It establishes the behavior of the <i>Slave</i> with respect to the <i>Master</i> being linked	0: <i>Slave</i> Setpoint = <i>Master</i> Setpoint The <i>Slave</i> operates in a twin way to the <i>Master</i> , regulates his speed at the same time 1: <i>Slave</i> Setpoint = <i>PID</i> setpoint The <i>Slave</i> operates independently to the <i>Master</i> , <i>PID</i> regulates your speed	0

If **FA44** = 0, and the installation does not demand pressure, the pump control will reduce the speed of **all the pumps at the same time** until the sleeping frequency, and will stop one by one after the **FA32** time, starting with the last *Slave* until ending sleeping the *Master* after **FA10** time. If during the deactivation cycle there was a pressure demand again, the deactivations would be suspended and the *Slaves* would be reactivated with the appropriate sequence.

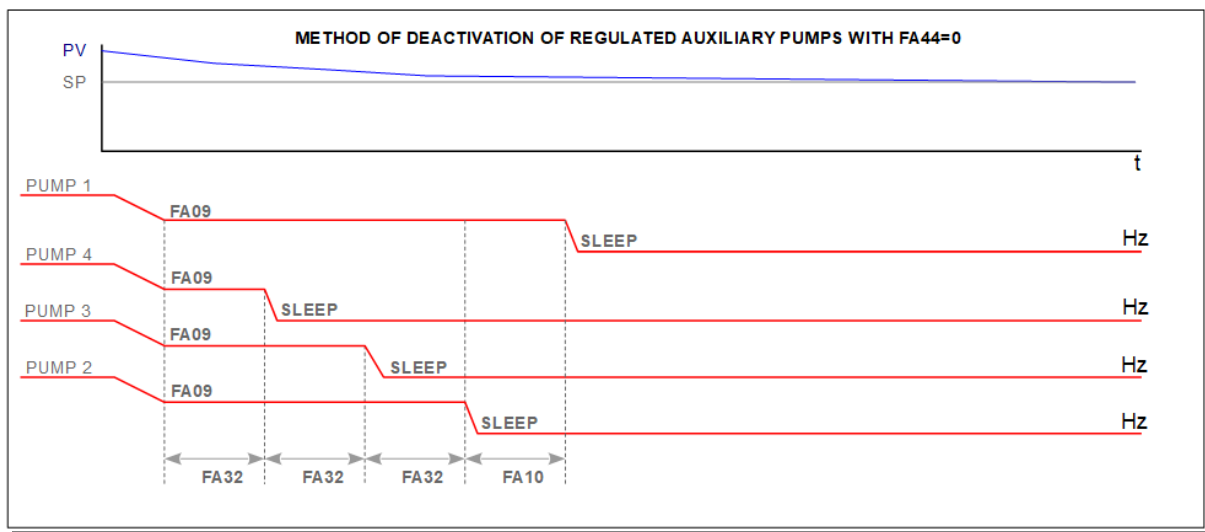

If **FA44** = 1, and the installation does not demand pressure, the pump control will reduce the speed of the last activated *Slave* to the sleeping frequency, and will make it fall asleep after the **FA32** time. Then the pump control will proceed in the same way with the next *Slave*, and so on until sleeping the *Master* after the **FA10** time. If during the deactivation cycle, there was a pressure demand again, the deactivations would be suspended and the *Slaves* would be reactivated with the appropriate sequence.

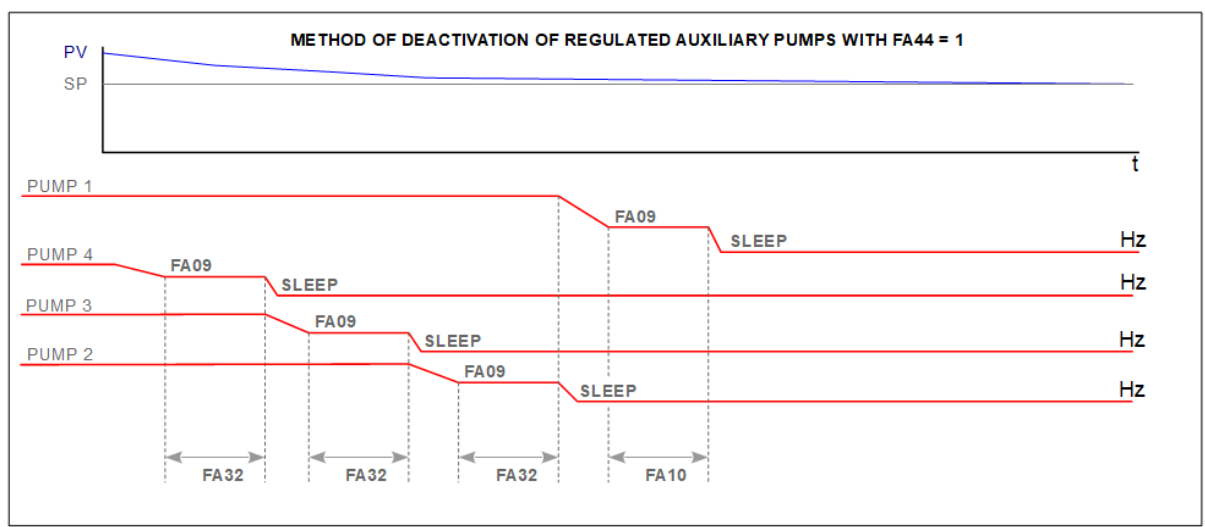



The operation of only the first four pumps has been represented. In the "All regulated" mode, the maximum number of linked pumps is 15.

9.6.- Automatic restart after voltage failures

It is possible that the pumping system will restart automatically after a power cut.

The parameters that control this function are described below, and they are in the parameter group [7.- Pump Control Menu: Parameter list: Control regulation:](#)

<i>Param.</i>	<i>Display / Use</i>	<i>Options/Range</i>	<i>Def.</i>
F213	 : Power-ON Autostart Autostart after a power drop	0 : Deactivated 1 : Activated	0
F215	 : Autostart - delay Autostart delay after power drop	0,1...3000,0 seconds	60,0 sec.



ATTENTION!!

It is the responsibility of the installer and the service technician to take the necessary precautions so that this action does not entail risks for the people who may be working on the pump, or in the group of pumps, if a power cut occurs.

9.7.- Auto-reset of the inverter alarms

Sometimes, especially in unattended pumping modes (well pumping, with solar limitation, etc ...) it is necessary that the inverter automatically performs the reset of alarms that may arise.









ATTENTION!!

For the AUTO-RESET operation works, if the **DIx** digital input start (F316 ~ F321 = 61) is not performed, the automatic restart function indicated above must have been activated previously.

The parameters that intervene in it (found in the **GENERAL FUNCTION** menu) are the following:

Param.	Display / Use	Options/Range	Def.
F214	 : Autostart after RESET Inverter-error AUTO-RESET	0 : Deactivated 1 : Activated	0
F216	 : Autostart - Nr.trials Number of error-reset tentative	0...100	0
F217	 : Error-Autoreset-delay Delay time for error-reset	0,0...3000,0 seconds	3,0 sec.
F343	 : DI1 delay ON <i>DI1</i> terminal is considered valid after waiting for the time set in F343	0,00 ~ 650,0 seconds	0 sec.
F344	 : DI2 delay ON <i>DI2</i> terminal is considered valid after waiting for the time set in F344	0,00 ~ 650,0 seconds	0 sec.
F345	 : DI3 delay ON <i>DI3</i> terminal is considered valid after waiting for the time set in F345	0,00 ~ 650,0 seconds	0 sec.
F346	 : DI4 delay ON <i>DI4</i> terminal is considered valid after waiting for the time set in F346	0,00 ~ 650,0 seconds	0 sec.
F347	 : DI5 delay ON <i>DI5</i> terminal is considered valid after waiting for the time set in F347	0,00 ~ 650,0 seconds	0 sec.
F348	 : DI6 delay ON <i>DI6</i> terminal is considered valid after waiting for the time set in F348	0,00 ~ 650,0 seconds	0 sec.
F349	 : DI7 delay ON <i>DI7</i> terminal is considered valid after waiting for the time set in F349	0,00 ~ 650,0 seconds	0 sec.
F350	 : DI8 delay ON <i>DI8</i> terminal is considered valid after waiting for the time set in F350	0,00 ~ 650,0 seconds	0 sec.
F351	 : DI1 delay OFF <i>DI1</i> terminal is considered invalid after waiting for the time set in F351	0,00 ~ 650,0 seconds	0 sec.
F352	 : DI2 delay OFF <i>DI2</i> terminal is considered invalid after waiting for the time set in F352	0,00 ~ 650,0 seconds	0 sec.
F353	 : DI3 delay OFF <i>DI3</i> terminal is considered invalid after waiting for the time set in F353	0,00 ~ 650,0 seconds	0 sec.

F354	 : DI4 delay OFF <i>DI4</i> terminal is considered invalid after waiting for the time set in F354	0,00 ~ 650,0 seconds	0 sec.
F355	 : DI5 delay OFF <i>DI5</i> terminal is considered invalid after waiting for the time set in F355	0,00 ~ 650,0 seconds	0 sec.
F356	 : DI6 delay OFF <i>DI6</i> terminal is considered invalid after waiting for the time set in F356	0,00 ~ 650,0 seconds	0 sec.
F357	 : DI7 delay OFF <i>DI7</i> terminal is considered invalid after waiting for the time set in F357	0,00 ~ 650,0 seconds	0 sec.
F358	 : DI8 delay OFF <i>DI8</i> terminal is considered invalid after waiting for the time set in F358	0,00 ~ 650,0 seconds	0 sec.
F732	 : Undervolt. threshold Minimum DC bus voltage to activate the LU alarm	According to inverter: Inverters 230Vac = range 120~1300V Inverters 400Vac = range 100~1300V	200Vdc 380Vdc

9.7.a.- Auto-reset LU alarm

There are two different behaviors when the auto-reset is performed. The behavior varies if it is carried out in the solar limitation mode or not (see [1.5.- Solar limitation mode](#)). Next we provide some graphs that will help to better understand that behavior.

9.7.a1.- Normal Auto-reset LU

When the inverter is not working in pumping mode with solar limitation (see [1.5.- Solar limitation mode](#)) the behavior of the auto-reset by low voltage alarm is that of the indicated in the following graphs, depending on whether the pump is running by DIx or automatically:

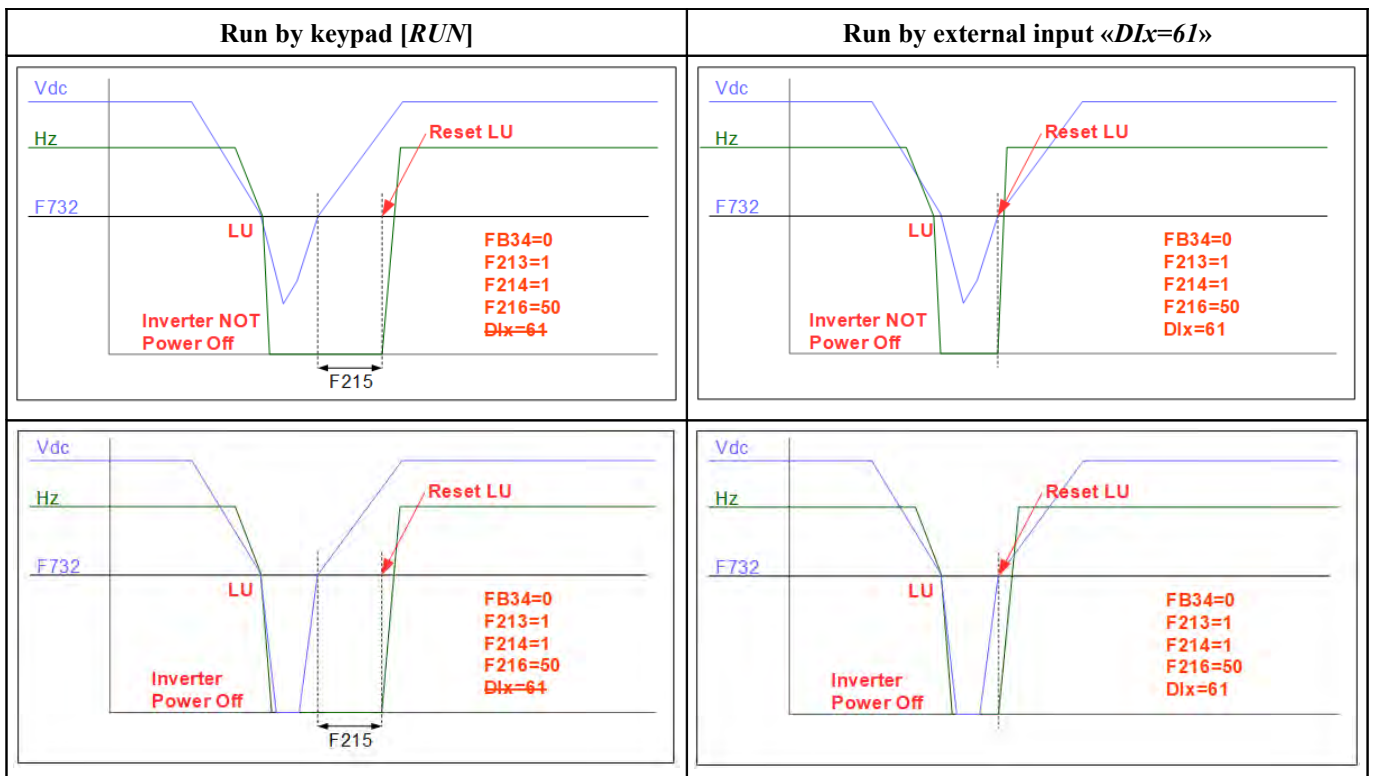

9.7.a2.- Auto-reset of LU in "Solar limitation" mode

When the inverter is working in pumping mode with solar limitation (see 1.5.- Solar limitation mode), the behavior of the auto-reset by low voltage alarm is as follows, depending on whether the pump is running by DIx or automatically:

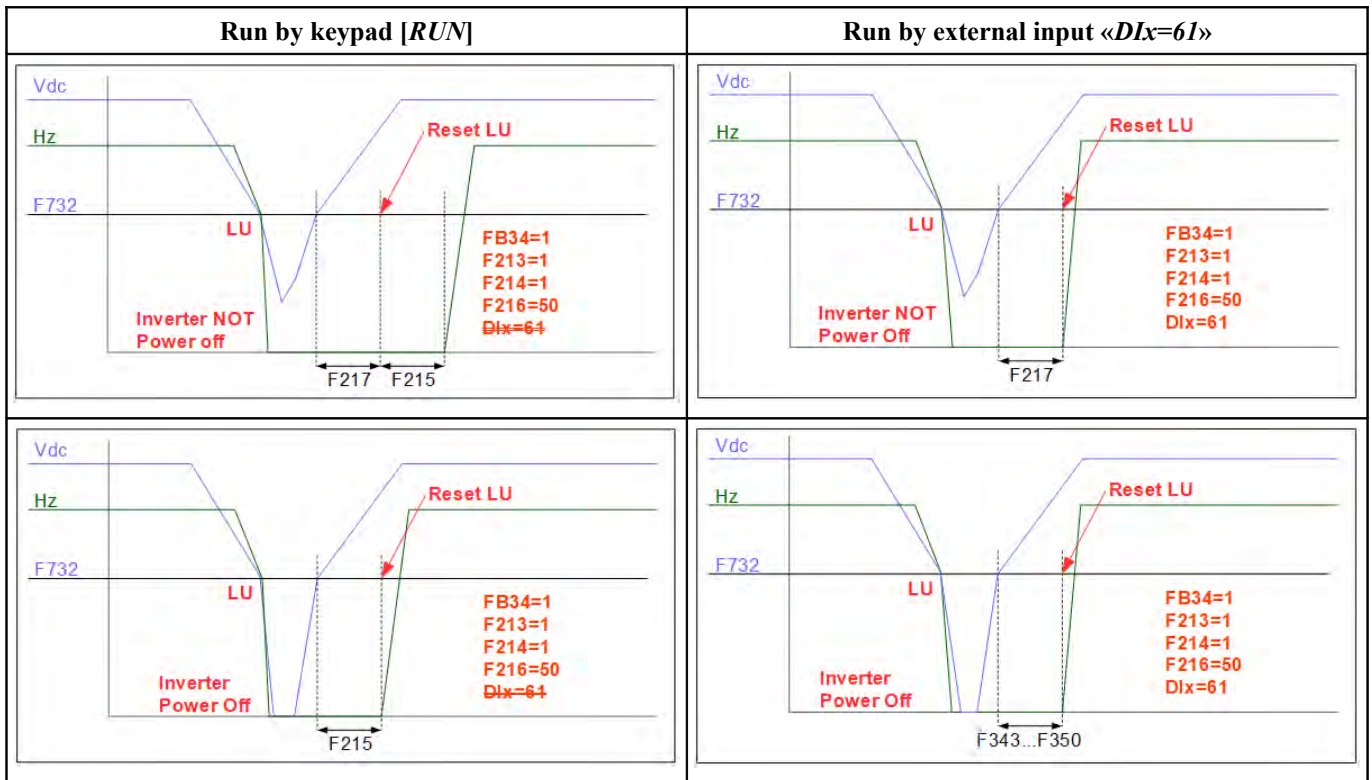

BLU S.r.l.



Via dell'Artigianato , 37 30030 VIGONOVO (VE)
 Ph. +39 049 9800318 Fax. +30 049 9800319
 Email: info@bludrive.it Web : www.bludrive.it

9.8.- Supervision of the analogic signal

The possibility of monitoring the analog signal coming from the sensor of the installation is available to enable the user to be informed of the breakage or failure of the measurement.

The parameters that intervene in the supervision are detailed below:

5.- Pump Control Menu: Parameter list: I / O Configuration

Param.	Display / Use	Options/Range	Def.
F300	 : Rel. func. assignment Configuration of the ROI output relay	18: Interruption of the analog signal	1
F301	 : DO1 func. assignment Configuration of the output transistor DO1		14
F302	 : DO2 func. assignment Configuration of output relay/transistor RO2/DO2		5

Choose the output that you want to activate in the event of cable or sensor breakage, and adjust it as indicated. Carry out this adjustment **ONLY** on the inverters that are physically connected to the measurement sensor.

6.- Pump Control Menu: Parameter List: PID Configuration

Param.	Display / Use	Options/Range	Def.
FA56	 : Main sensor fault Activate Main sensor failure control (output)	0 : Deactivated 1 : Message. Error Aer0	0

9.7.a2.- Auto-reset of LU in "Solar limitation" mode

If the fault of the analog is detected in the working mode of [Simple Pump](#) or [Regulated + fixed](#) the output is activated and the pump stops directly.

If the analog fault is detected in a [All regulated working mode](#), **and more than one sensor is installed**, the behavior is different.

Only the inverter that has the sensor connected and whose output (digital or relay) has been parameterized to 18, will activate the output when the breakage or failure of the sensor is detected. The reading of the **PV** values for the **PID** will automatically be carried out by another sensor of the pump chain. In addition, this fault will be reported on the display.

 <p>The display shows: ALM, LOC/REM, FWD, REV, STOP. Date: 06/27/2019 10:47:42. SP: 6.0 bar, PV: 5.4 bar, S: 0.00 Hz, 0.00 A.</p>	 <p>The display shows: ALM, LOC/REM, FWD, REV, STOP. Date: 06/27/2019 10:46:05. SP: 6.0 bar, ⊗PV: 5.4 bar, S: 0.00 Hz, 0.00 A.</p>
Inverter without sensor fault	Inverter with sensor fault

The logo consists of the letters 'BLU' in a bold, blue, sans-serif font. The letters are closely spaced and centered horizontally on the page. There is a small horizontal line at the top left and a vertical black bar on the left side of the page.

BLU S.r.l.

Via dell'Artigianato , 37 30030 VIGONOVO (VE)

Ph. +39 049 9800318 Fax. +30 049 9800319

Email: info@bludrive.it Web : www.bludrive.it